

PROXIMITY SENSORS

2022

Proximity Sensors

Index



Inductive sensors - Cubic 40x40 page 4

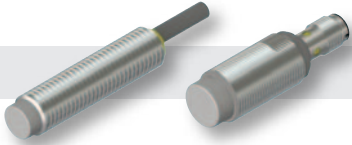

Inductive sensors - Round page 10

Proximity Sensors

Inductive sensors - Cubic 40x40 - Summary

APPROVALS: UL 508

UL CATEGORY: NRKH FILE: E506808

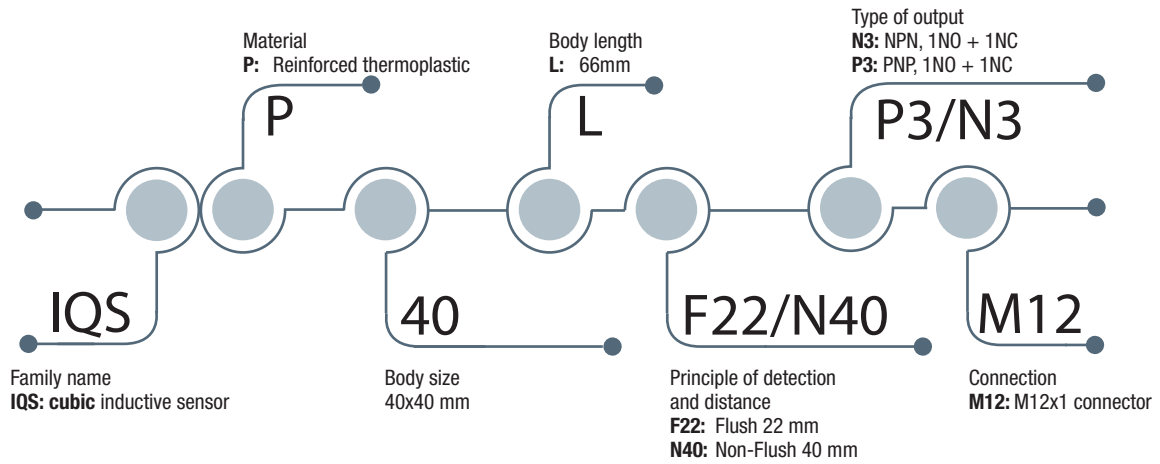

HOW IS IT MADE?

- 01 Sensitive part**
 - Flush or non flush, tournable head
- 02 Fixing**
 - Push-lock mounting system
- 03 Signalling**
 - 4 LEDs in the corners, status indication or problem detection
- 04 Connection**
 - M12 x 1, 4 pin, male connector



Proximity Sensors

Inductive sensors - Cubic 40x40 - Summary

APPLICATIONS

- Non contact detection of metal objects in general position-sensing and presence-sensing in industrial applications
- Conveyor systems, material handling and logistic, agriculture, escalators.

DESCRIPTION

Inductive proximity sensors with 40 mm x 40 mm rectangular housings for use in harsh ambient conditions to detect metal objects without contact and wear-free. The sensors generate an electromagnetic field which interacts with the detected object and are characterized by a long service life and extreme ruggedness. The long sensing distance of up to 40 mm makes them particularly suitable also for use in conveyor systems, assuring a stable and reliable detection even in harsh environments, also thanks to the integrated advanced electronics which ensures optimal performance with temperature variations.

MAIN FEATURES

- Easy and quick mounting or replacement without the need of additional tools thanks to the plug-and-play mounting system.
- The turnable head in different positions allows greater flexibility in all applications.
- The detection is reliable and accurate over the entire temperature range, thanks to the advanced integrated electronics.
- Safer installation thanks to the long sensing range up to 40 mm.
- Reliable switching performance even in harsh environments with low and high temperature (-25°C to +80°C).
- Degree of protection IP68, IP69K.
- Sensor switching and operating status can be clearly seen from any directions thanks to the 4 corner LEDs.
- Integrated diagnostic functions with flashing LEDs in the event of short-circuit or overload.

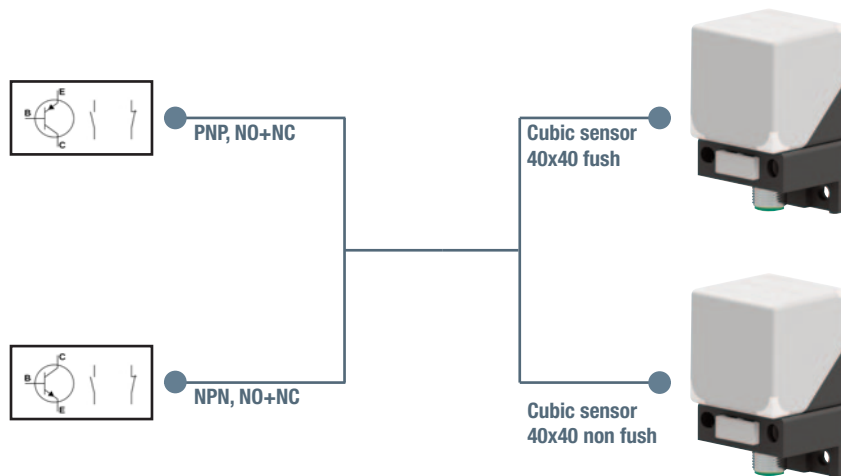

Proximity Sensors

Inductive sensors - Cubic - 40x40 mm - Technical Data

CUBIC SENSOR	
POWER SUPPLY	
Rated operational voltage (U_b)	10 to 30 VDC (ripple included)
Ripple (U_{rpp})	$\leq 10\%$
No load supply current (I_o)	≤ 20 mA
Power ON delay (t_v)	≤ 50 ms
Output functions	NPN or PNP by sensor type open collector
Output configuration	N.O and N.C.
OUTPUTS	
Output current (I_o)	≤ 200 mA
OFF-state current (I_r)	≤ 100 μ A
Voltage drop (U_d)	Max. 2.5 VDC @ 200 mA
Protection	Reverse polarity, short-circuit and overload
Voltage transient	1 kV/0.5 J
RESPONSE TIMES	
Max. operating frequency (f)	≤ 200 Hz
INDICATION	
Indication for Target not present	Green LED ON, Yellow LED OFF, Output OFF
Indication for Target present	Green LED ON, Yellow LED ON, Output ON
Indication for short circuit/overload	LED blinking (f = 2 Hz)
ENVIRONMENTAL	
Ambient temperature Operating	-25° to +80°C (-13° to +176°F)
Ambient temperature Storage	-25° to +80°C (-13° to +176°F)
Ambient humidity Operating	35% to 95%
Ambient humidity Storage	35% to 95%
Vibration	10 to 55 Hz, amplitude 1.0 mm; sweep cycle 5 min; in X, Y and Z direction IEC 60068-2-6
Shock	30 G /11 ms. 10 shocks in X, Y and Z direction IEC 60068-2-27
Degree of protection	IP67, IP68 (1m submersion for 24h) IP69K
EMC AND CONFORMITY	
EMC protection IEC 60947-5-2	
IEC 61000-4-2 Electrostatic discharge	8 kV air discharge 4 kV contact discharge
IEC 61000-4-3 Radiated radiofrequency	3 V/m
IEC 61000-4-4 Burst immunity	2 kV
IEC 61000-4-6 Conducted radio frequency	3 V
MTTF _d	1900 years @ 50°C (122°F)
Approvals	CE cULus UKCA
MECHANICAL DATA	
Mounting	Flush or non flush mountable
Material housing	PBT glass fibres
Weight max (including mounting bracket)	Flush 116g Non-flush 128g
Max tightening torque	M12 connector: 3Nm Mounting bracket: 1Nm
ELECTRICAL CONNECTION	
Plug	M12x1, 4 pin, male connector

Proximity Sensors

Inductive sensors - Cubic - 40x40 mm - Installation

Flush

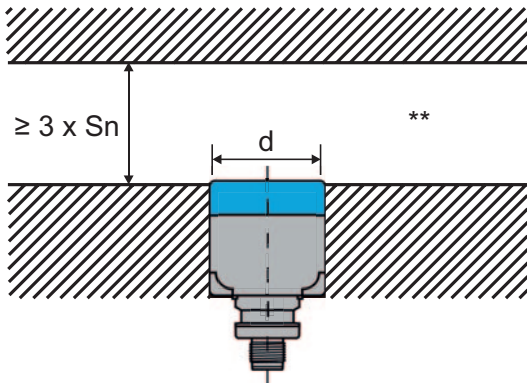

Flush sensor, when installed in damping material

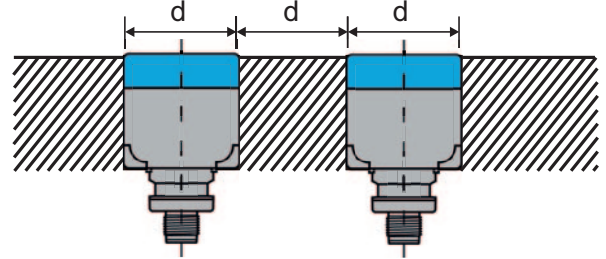

Flush sensors, when installed together in damping material

Non-flush

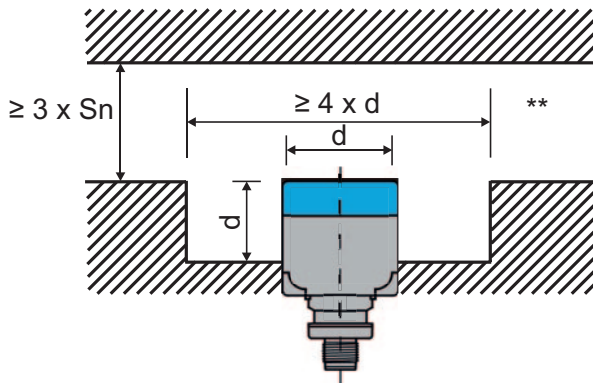

Non-flush sensor, when installed in damping material

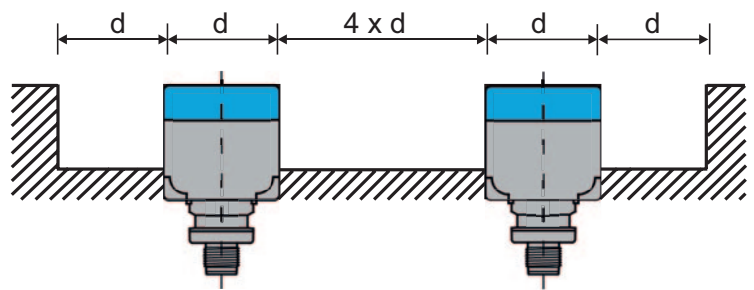

Non-flush sensors, when installed together in damping material

Sensor installed opposite each other

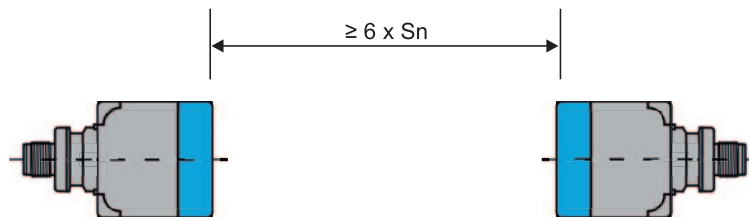

For sensors installed opposite each other, a minimum space of $6 \times S_n$ (the nominal sensing distance) must be observed

** Free zone or non-dampig material
 S_n : nominal sensing distance
 d: 40 mm

Proximity Sensors

Inductive sensors - Cubic - 40x40 mm - Elements tabel

CORRECTION FACTORS

The specific operating distance S_{η} refers to defined measuring conditions. The following data have to be considered as general guidelines.

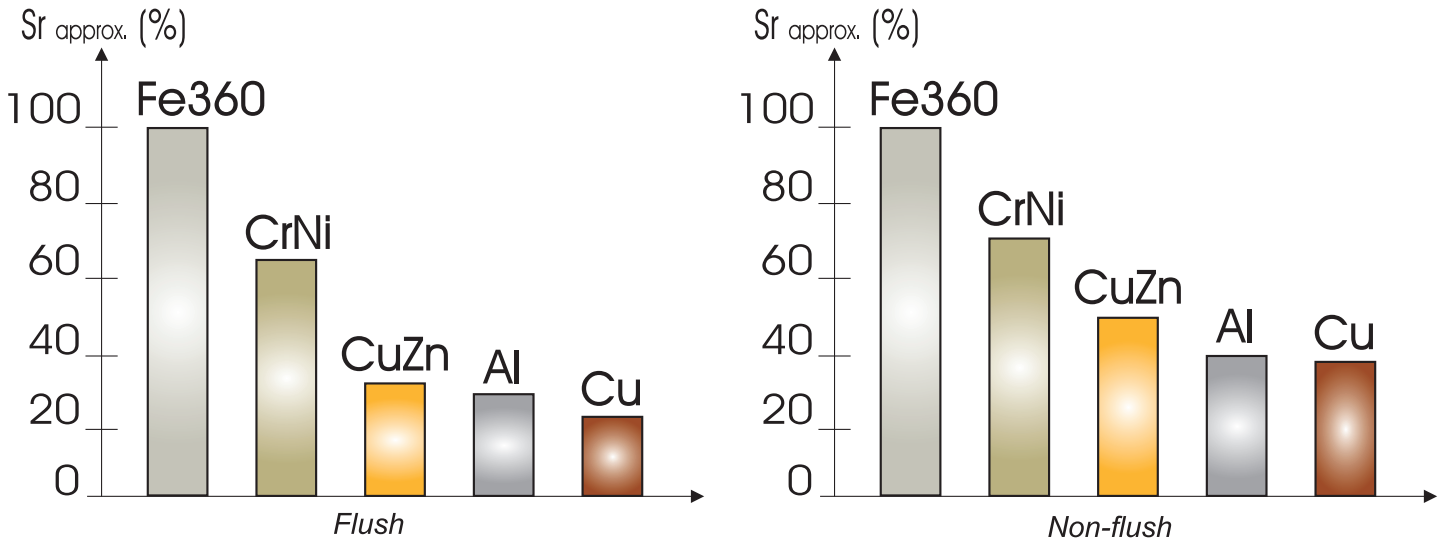

Fe360: Steel; **CrNi:** Chrome-nickel; **CuZn:** Brass; **Al:** Aluminium; **Cu:** Copper; **Sr:** Effective operating distance.

The rated operating distance is reduced by the use of metals and alloys other than Fe360. The most important reduction factors for inductive proximity sensors are shown in the figure.

ACCURACY

Repeat accuracy (R) ≤ 5%

Proximity Sensors

Inductive sensors - Cubic - 40x40 mm

Electrical connection:
M12: M12x1 connector

P40 Cubic sensor
with M12 connector



Connection Diagram
PNP

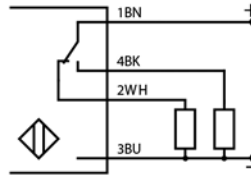

BN: Brown | WH: White | BK: Black | BU: Blue

M12 Connector

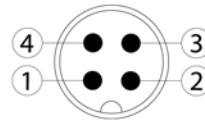

Connection Diagrams
NPN

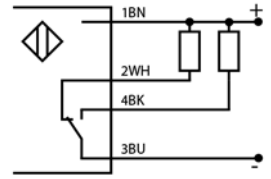

BN: Brown | WH: White | BK: Black | BU: Blue

M12 Connector

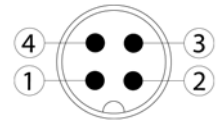

Output type

Weight

128 g

PNP, 1NO + 1NC	IQSP40LF22P3M12	Flush sensor, nominal operating distance Sn 22mm
PNP, 1NO + 1NC	IQSP40LN40P3M12	Non flush sensor, nominal operating distance Sn 40mm
NPN, 1NO + 1NC	IQSP40LF22N3M12	Flush sensor, nominal operating distance Sn 22mm
NPN, 1NO + 1NC	IQSP40LN40N3M12	Non flush sensor, nominal operating distance Sn 40mm

DIMENSIONS

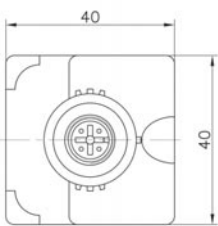

Sensor dimensions

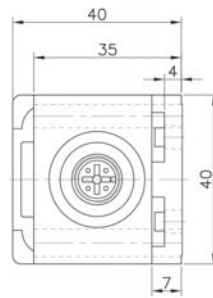
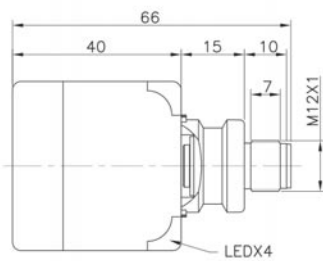

Sensor dimensions with bracket

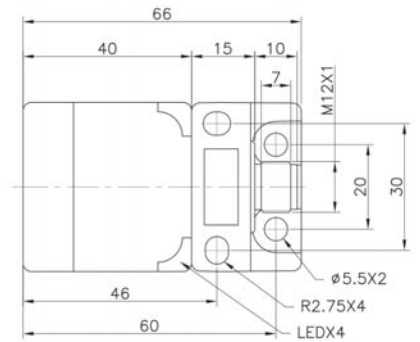

Proximity Sensors

Inductive sensors - Round - Summary

APPROVALS: UL 508 | UL CATEGORY: NRKH FILE: E506808

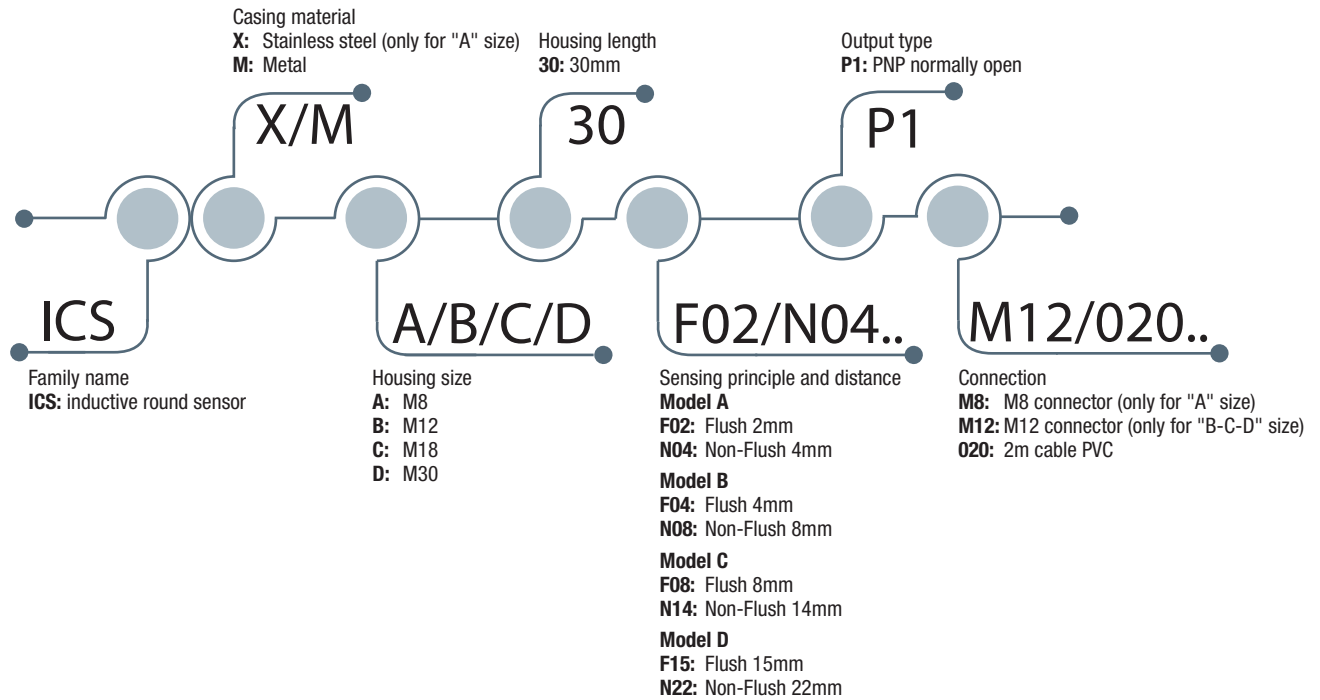

HOW IS IT MADE?

01 Sensing face

- Flush
- Non-flush

02 Fixing

- Easy mounting
- Two nuts for sensor fixing
- Four sizes for sensor: M8, M12, M18, M30

03 Signalling

- Yellow LED visible from every angle
- Flashing output: short circuit or overload indication

04 Connection

- M8 connector
- M12 connector
- 2m cable PVC

05 Main features

- Accurate sensing and suitable for fast speed operations
- Assured traceability and best application control
- Environmentally friendly potting material

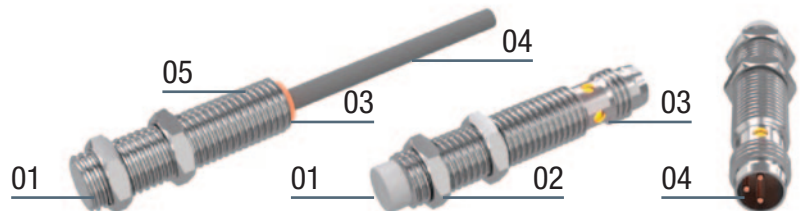

Proximity Sensors

Inductive sensors - Round - Description

APPLICATIONS

Machine tool

- CNC machine tool.
- Drill machine.

Inductive sensors are used to check the tool position when changing the tool or to verify the component moved to the correct location.

Agriculture

- Thanks to its excellent quality and to the complete product range, ICS series is particularly suitable for the agricultural and earth-moving sectors.

Material handling systems

- In these systems it is mandatory to ensure the automation and reliable flow of goods. Inductive sensors are critical to obtaining the higher productivity and quality from the automated process.

DESCRIPTION

The robust and highly reliable ICS series is now available in increased operating distance. In M8, M12, M18 and M30 stainless steel or nickel plated brass housings. These sensors are extremely accurate and represent the best choice for non-contact detection of metallic targets at a distance up to 40 mm, the largest sensing distance available on the market for an inductive sensor. The powerful design of ICS offers the ideal solution in demanding installation conditions typical of industrial environments. The eco-friendly high performance potting material protects the electronic components and provides increased reliability with higher resistance to mechanical stress and vibrations than the traditional proximity sensors. ICS inductive proximity sensors thanks to an operating distance up to 3 times the standard, allows to position the sensor at a higher distance from a metal target. The result is an increased sensor's lifetime especially when the metal target has greater tolerances, being the sensor well protected. A. The sensors are rated to IP67 and the mechanical design of the back part ensures an excellent sealing against water and humidity penetration. Thanks to the built in microcontroller, all sensors are individually compensated to ensure repeatable and highly accurate operation over the whole temperature range, granting the sensing distance between -25 and +70°C (-13° to +158°F).

They comply with the requirements of European Directives (Low Voltage and RoHS) and are conform to European and International Standards.

The CE declaration of these products are available in the download section of website www.comepi.it or by writing to the following email address: tecnico@comepi.it
DDC12 - Proximity sensors

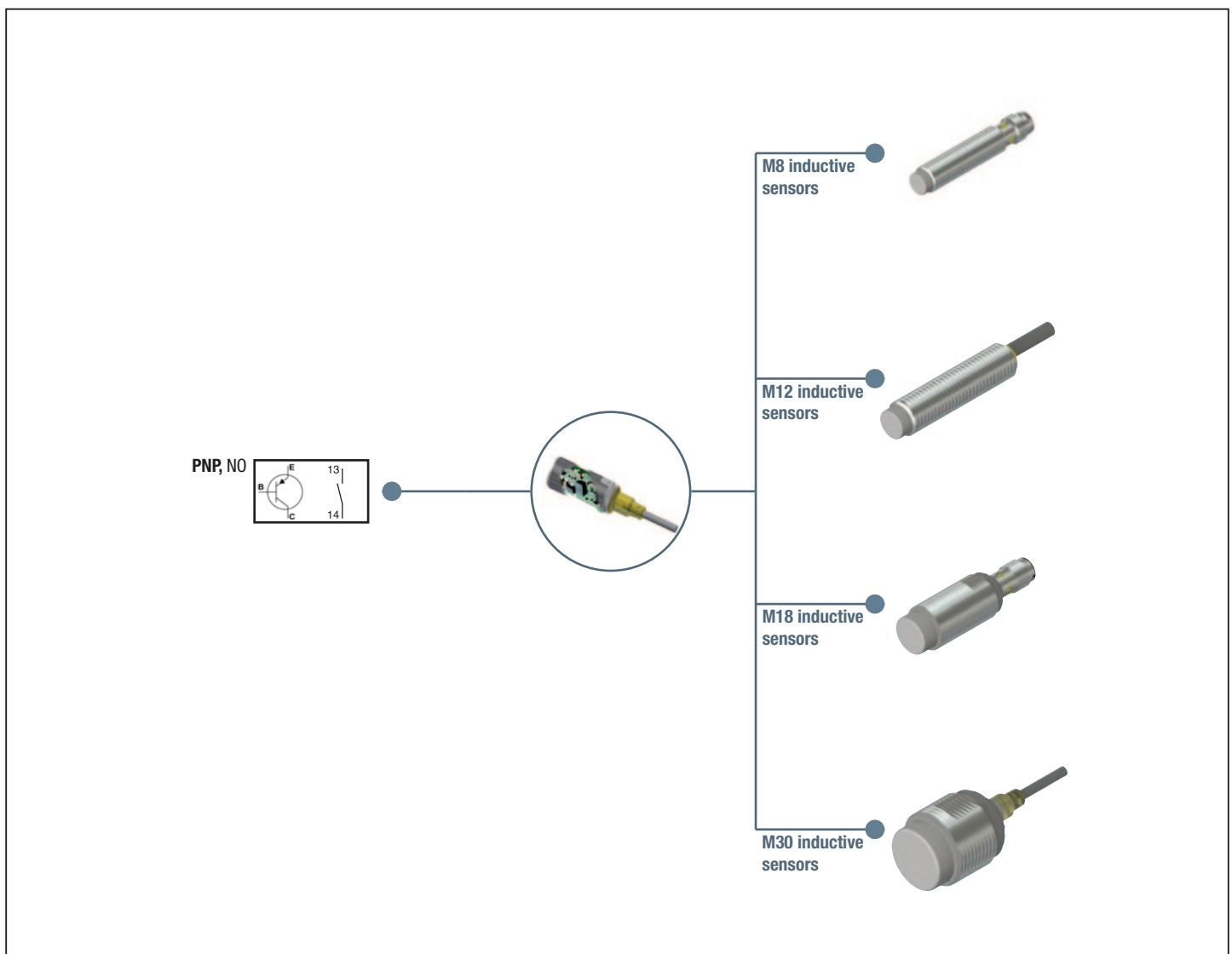

Proximity Sensors

Inductive sensors - Round - Technical Data

	M8	M12
	POWER SUPPLY	
Rated operational voltage (U_b)	10 to 36 VDC (ripple included)	
Ripple (U_{rpp})	≤ 10%	
No load supply current (I_o)	≤ 16 mA	≤ 15 mA
Power ON delay (t_v)	≤ 20 ms	
	OUTPUTS	
Output current (I_o)	≤ 200 mA @ 50°C ≤ 150 mA @ 50-80°C)	≤ 200 mA @ 50°C ≤ 150 mA @ 50-70°C)
OFF-state current (I_r)	≤ 50 μA	
Voltage drop (U_d)	Max. 1.6 VDC @ 200 mA	Max. 2.5 VDC @ 200 mA
Protection	Reverse polarity, short-circuit, transients	
Voltage transient	1 kV/0.5 J	
	RESPONSE TIMES	
Max. operating frequency (f)	≤ 2000 Hz	
	INDICATION	
Indication for output ON	Activated LED, yellow	
NO version	Target present	
Indication for short circuit/overload	LED blinking (f = 2 Hz)	
	ENVIRONMENTAL	
Ambient temperature Operating	-25° to +80°C (-13° to +176°F)	-25° to +70°C (-13° to +158°F)
Ambient temperature Storage	-30° to +80°C (-22° to +176°F)	
Ambient humidity Operating	35% to 95%	5% to 95% humidity, non-condensing
Ambient humidity Storage	35% to 95%	5% to 95% humidity, non-condensing
Vibration	10 to 55 Hz, amplitude 1.0 mm; sweep cycle 5 min; in X, Y and Z direction IEC 60068-2-6	IEC 60947-5-2/7.4
Shock	30 G /11 ms. 10 shocks in X, Y and Z direction IEC 60068-2-27	IEC 60947-5-2/7.4
Degree of protection	IP67	
	EMC AND CONFORMITY	
EMC protection IEC 60947-5-2		
IEC 61000-4-2 Electrostatic discharge	8 kV air discharge 4 kV contact discharge	
IEC 61000-4-3 Radiated radiofrequency	3 V/m	
IEC 61000-4-4 Burst immunity	2 kV	
IEC 61000-4-6 Conducted radio frequency	3 V	
IEC 61000-4-8 Power frequency magnetic fields	30 A/m	
MTTF _d	2914 years @ 50°C (122°F)	750 years @ 50°C (122°F)
Approvals	CE cULus	CE cULus
	MECHANICAL DATA	
Mounting	Flush or non flush mountable	
Material housing	Stainless steel AISI304	nickel-plated brass
Material front cap	Grey thermoplastic polyester	
Max tightening torque	7 Nm	10 Nm
	ELECTRICAL CONNECTION	
Cable	2m, 3 x 0.14 mm ² , Ø3.2 mm PVC, grey, oil proof, laser write	2m, 3 x 0.25 mm ² , Ø4.1 mm grey PVC, oil proof
Connector	M8 male connector	M12 male connector

Proximity Sensors

Inductive sensors - Round - Technical Data

	M18	M30
	POWER SUPPLY	
Rated operational voltage (U_b)	10 to 36 VDC (ripple included)	
Ripple (U_{rpp})	≤ 10%	
No load supply current (I_0)	≤ 15 mA	
Power ON delay (t_v)	≤ 20 ms	≤ 300 mA
	OUTPUTS	
Output current (I_o)	≤ 200 mA @ 50°C ≤ 150 mA @ 50-70°C)	
OFF-state current (I_r)	≤ 50 μA	
Voltage drop (U_d)	Max. 2.5 VDC @ 200 mA	
Protection	Reverse polarity, short-circuit, transients	
Voltage transient	1 kV/0.5 J	
	RESPONSE TIMES	
Max. operating frequency (f)	≤ 1500 Hz	≤ 1000 Hz
	INDICATION	
Indication for output ON	Activated LED, yellow	
NO version	Target present	
Indication for short circuit/overload	LED blinking (f = 2 Hz)	
	ENVIRONMENTAL	
Ambient temperature Operating	-25° to +70°C (-13° to +158°F)	cable: -25° to +70°C (-13° to +158°F) plug: -40° to +70°C (-22° to +158°F)
Ambient temperature Storage	-30° to +80°C (-22° to +176°F)	-40° to +80°C (-22° to +176°F)
Ambient humidity Operating	5% to 95% humidity, non-condensing	
Ambient humidity Storage	5% to 95% humidity, non-condensing	
Vibration	IEC 60947-5-2/7.4	IEC 60947-5-2/7.4
Shock	IEC 60947-5-2/7.4	IEC 60947-5-2/7.4
Degree of protection	IP67	
	EMC AND CONFORMITY	
EMC protection IEC 60947-5-2		
IEC 61000-4-2 Electrostatic discharge	8 kV air discharge 4 kV contact discharge	
IEC 61000-4-3 Radiated radiofrequency	3 V/m	12 V/m
IEC 61000-4-4 Burst immunity	2 kV	4 kV
IEC 61000-4-6 Conducted radio frequency	3 V	10 V
IEC 61000-4-8 Power frequency magnetic fields	30 A/m	
MTTF _d	550 years @ 50°C (122°F)	
Approvals	CE cULus	CE cULus
	MECHANICAL DATA	
Mounting	Flush or non flush mountable	
Material housing	nickel-plated brass	
Material front cap	Grey thermoplastic polyester	
Max tightening torque	25 Nm	
	ELECTRICAL CONNECTION	
Cable	2m, 3 x 0.25 mm ² , Ø4.1 mm grey PVC, oil proof	2m, 3 x 0.34 mm ² , Ø5.2 mm grey PVC, oil proof
Connector	M12 male connector	

Proximity Sensors

Inductive sensors - Round - Installation

The given values are minimum values. They cause changes of the sensing range less than 10%.
Cylindrical proximity switches devices with the same diameter may have different switching distances.

The following table shows typical examples:

Diameter (mm)	Switching distance Sn	
	flush	non flush
8	2	4
12	4	8
18	8	14
30	15	22

An inductive proximity switch utilizes coils for generating the electromagnetic field. To achieve a particular direction of the field these coils are wound in an encapsulated core. Nonetheless, some of this fields will radiate sideways. To avoid these products with a large range to be already attenuated by the environment, a clear space must be created around the sensor element complying with the minimum values in the following table.

Dimensions (mm)			
A	B	C	F
$\geq 2 \times S_n$	$B \geq D$ $B \geq 1.5 D^*$	$\geq 3 \times S_n$	flush $F = D$ non flush $F = 3 \times D$

*Only for sensor M30

The safe assured release distance is guaranteed at a minimum distance to a measurement plate (target)/metal environment of at least $3 \times S_n$.

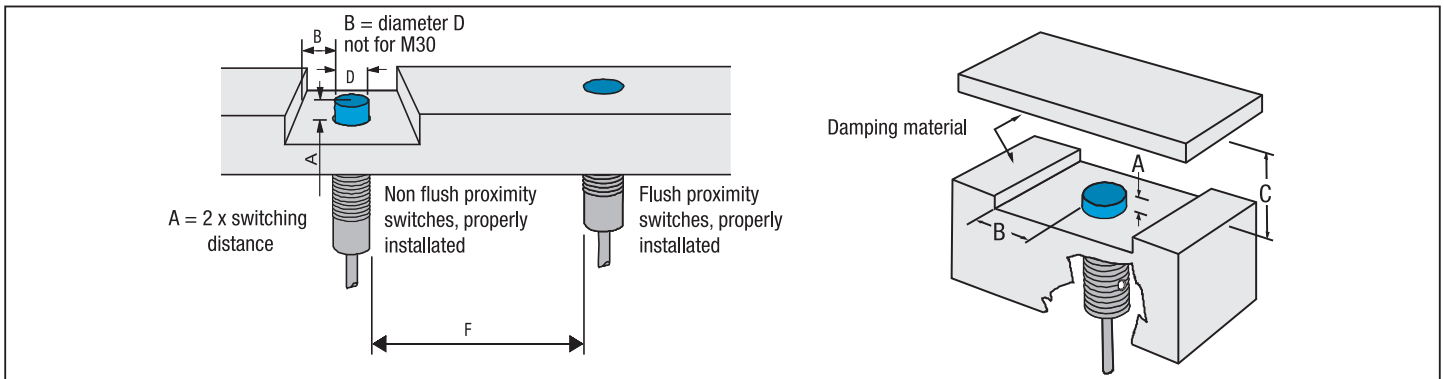

The minimum distances F specified in the table above must be kept to prevent any mutual interference.

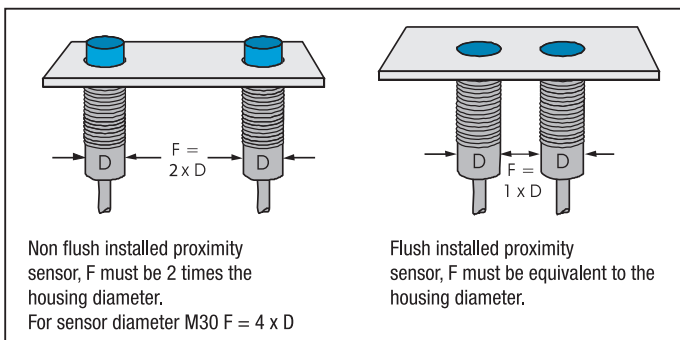

see pag 8 for **CORRECTION FACTORS**

Sensors installed opposite each other

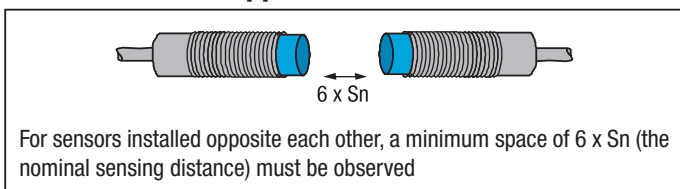

Cable version

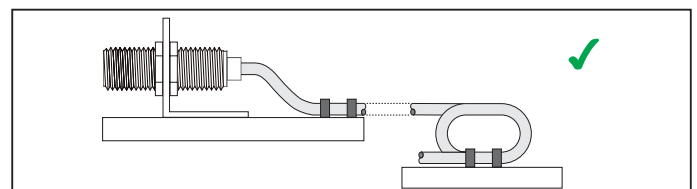



Proximity Sensors

Inductive sensors - Round - M8

Electrical connection:

M8: M8 connector

O20: Cable length 2m.

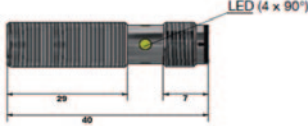
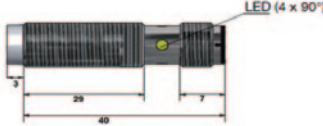
	M8 Flush sensor with M8 connector	M8 Non flush sensor with M8 connector	Connection M8
			
			
Output type	Rated operating distance Sn Weight	2 mm 16 g	Rated operating distance Sn Weight
		4 mm 16 g	

PNP, NO

ICSXA30F02P1M8

ICSXA30N04P1M8

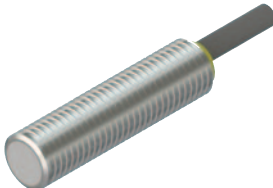
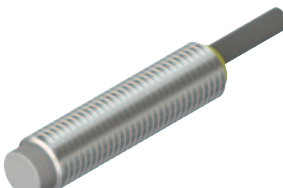
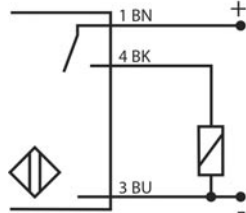
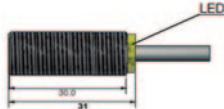
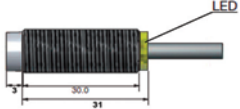
	M8 Flush sensor with cable	M8 Non flush sensor with cable	Connection Diagrams
			
			
Output type	Rated operating distance Sn Weight	2 mm 45 g	Rated operating distance Sn Weight
		4 mm 45 g	

PNP, NO

ICSXA30F02P1020

ICSXA30N04P1020

Proximity Sensors

Inductive sensors - Round - M12

Electrical connection:

M12: M12 connector

O20: Cable length 2m.

M12 Flush sensor with M12 connector

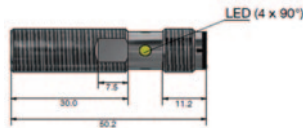

Rated operating distance Sn 4 mm
Weight 30 g

M12 Non flush sensor with M12 connector

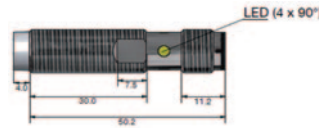
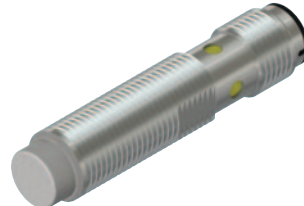

Rated operating distance Sn 8 mm
Weight 30 g

Connection M12

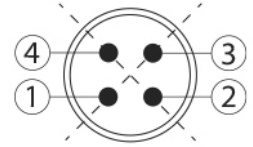

Output type

PNP, NO

ICSMB30F04P1M12

ICSMB30N08P1M12

M12 Flush sensor with cable

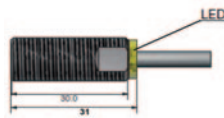
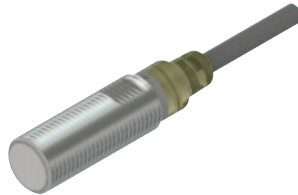

Rated operating distance Sn 4 mm
Weight 120 g

M12 Non flush sensor with cable

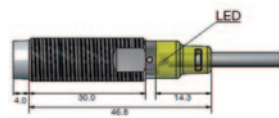

Rated operating distance Sn 8 mm
Weight 120 g

Connection Diagrams

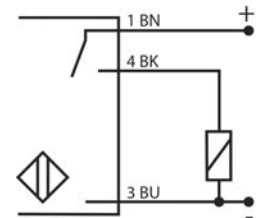

Output type

PNP, NO

ICSMB30F04P1020

ICSMB30N08P1020

Proximity Sensors

Inductive sensors - Round - M18

Electrical connection:

M18: M12 connector

O20: Cable length 2m.

M18 Flush sensor with M12 connector

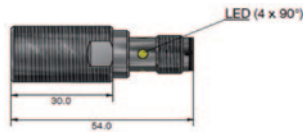

Rated operating distance Sn 8 mm
Weight 70 g

M18 Non flush sensor with M12 connector

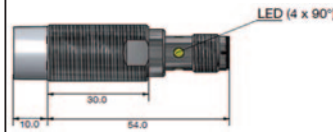

Rated operating distance Sn 14 mm
Weight 70 g

Connection M12

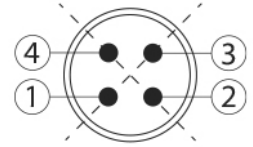

Output type

PNP, NO

ICSMC30F08P1M12

ICSMC30N14P1M12

M18 Flush sensor with cable

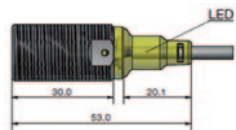

Rated operating distance Sn 8 mm
Weight 150 g

M18 Non flush sensor with cable

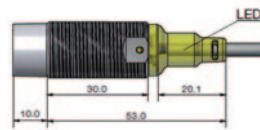

Rated operating distance Sn 14 mm
Weight 150 g

Connection Diagrams

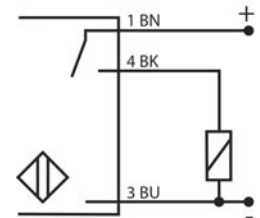

Output type

PNP, NO

ICSMC30F08P1020

ICSMC30N14P1020

Proximity Sensors

Inductive sensors - Round - M30

Electrical connection:

M30: M12 connector

O20: Cable length 2m.

M30 Flush sensor with M12 connector

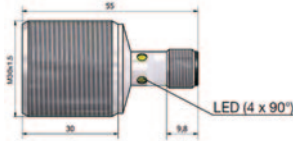

Rated operating distance Sn 15 mm
Weight 185 g

M30 Non flush sensor with M12 connector

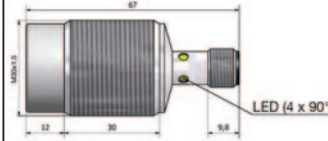

Rated operating distance Sn 22 mm
Weight 185 g

Connection M12

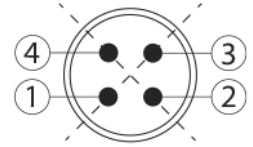

Output type

PNP, NO

ICSMD30F15P1M12

ICSMD30N22P1M12

M30 Flush sensor with cable

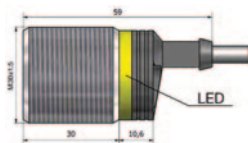

Rated operating distance Sn 15 mm
Weight 190 g

M30 Non flush sensor with cable

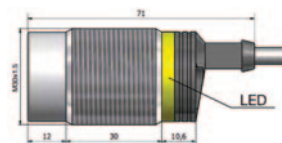

Rated operating distance Sn 22 mm
Weight 190 g

Connection Diagrams

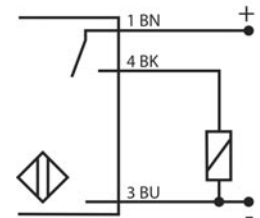

Output type

PNP, NO

ICSMD30F15P1020

ICSMD30N22P1020

Proximity Sensors

Inductive sensors - Accessories

Bracket

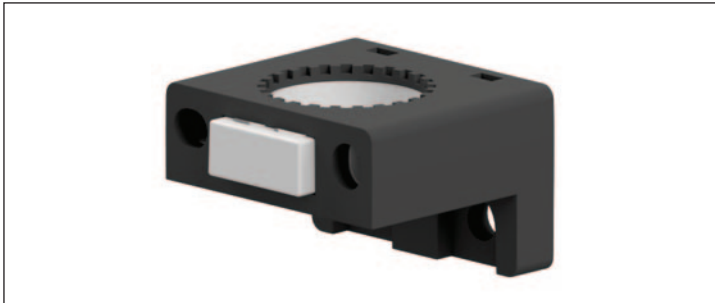

Description	Code
Replacement bracket for cubic sensor IQS	GR 1707

Connection cable

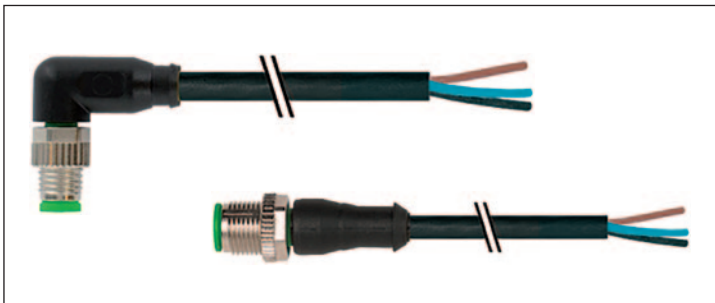

Description	Poles	Lenght	Code
M8 female connection cable	3	3m	XX3D030SM8
M8 female connection cable	3	5m	XX3D050SM8
90° M8 female connection cable	3	3m	XX3A030SM8
90° M8 female connection cable	3	5m	XX3A050SM8
M12 female connection cable	4	3m	XX4D030SM
M12 female connection cable	4	5m	XX4D050SM
90° M12 female connection cable	4	3m	XX4A030SM
90° M12 female connection cable	4	5m	XX4A050SM

Notes

A large grid area for taking notes, consisting of a 30x30 grid of small squares. The grid is contained within a rounded rectangular border.

Notes

A large grid area for taking notes, consisting of a 30x30 grid of small squares. The grid is contained within a rounded rectangular border.

Notes

A large, empty grid area for taking notes, consisting of a 30x30 grid of small squares. The grid is contained within a rounded rectangular border.

COMEPI AROUND THE WORLD

Comepi products are available all over the world, the company supplies 76 countries in 5 continents. Our focus on flexibility translates into the ability to create solutions where the market requires new application needs. Comepi has a network of agents and importers, supported by local distributors. This organization ensures global presence and support.



23899 Robbiate
(Lecco) Italy
Via Novarino 9/L
tel. +039 990 6408
+039 990 6203
comepi@comepi.it
comepi.eu

 **COMEPI**



CAT140-SC0922-PX