

SUSPENDED INSTALLATION

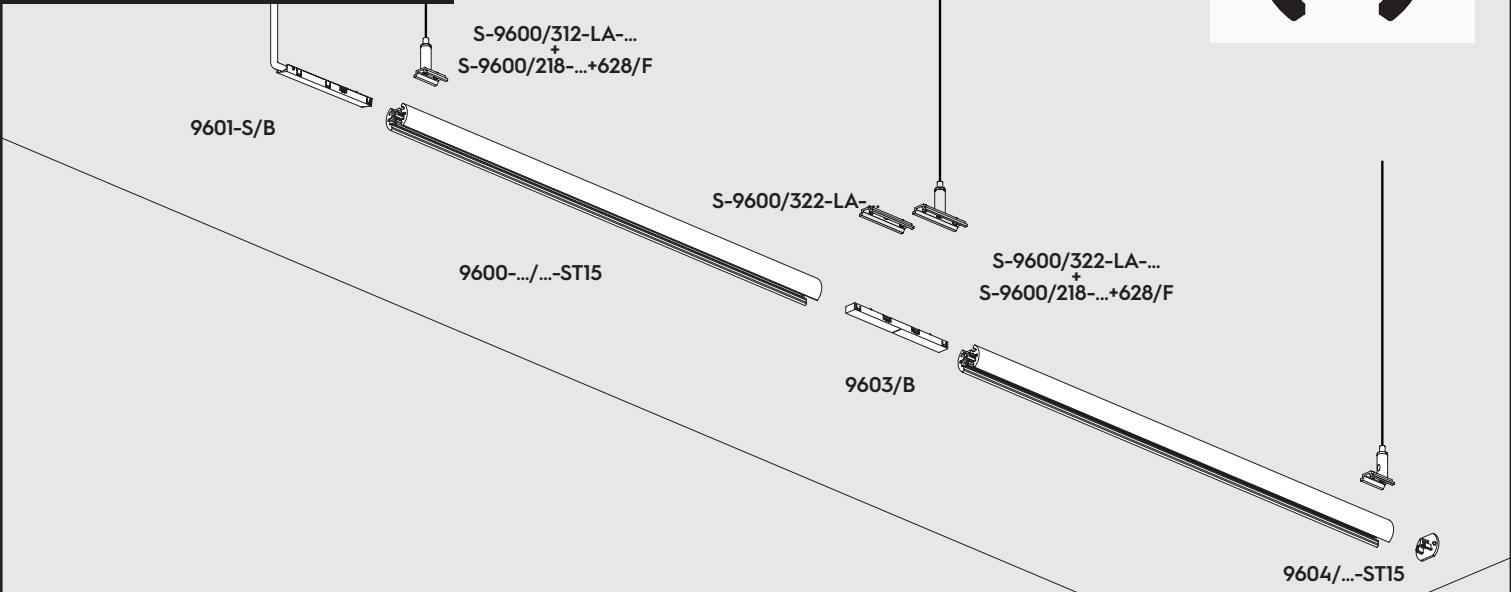

1 - 9600-.../...-ST15

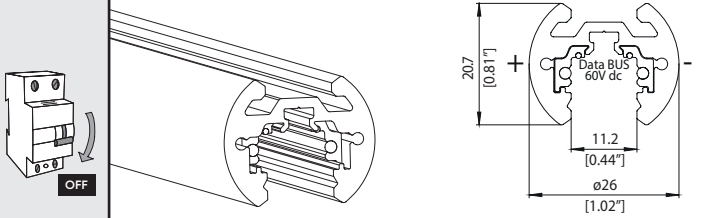

CODE	L mm [ft]
9600-1/...-ST15	1000 [3.28']
9600-2/...-ST15	2000 [6.56']
9600-3/...-ST15	3000 [9.84']

2 - USE

Suspended

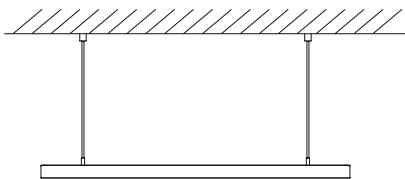

3 - SUSPENDED FIXING

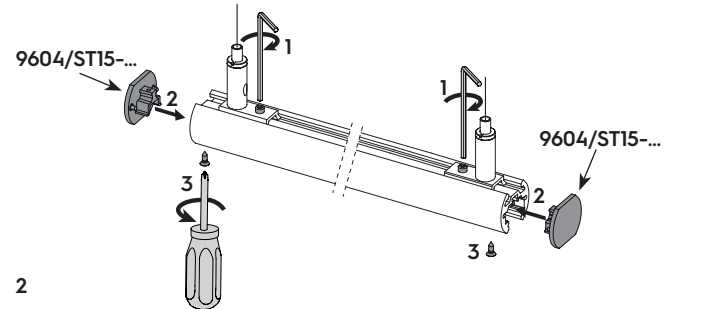
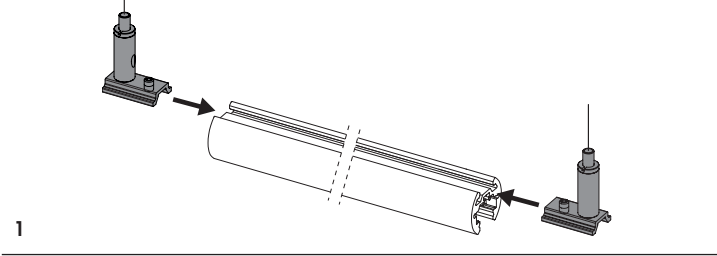
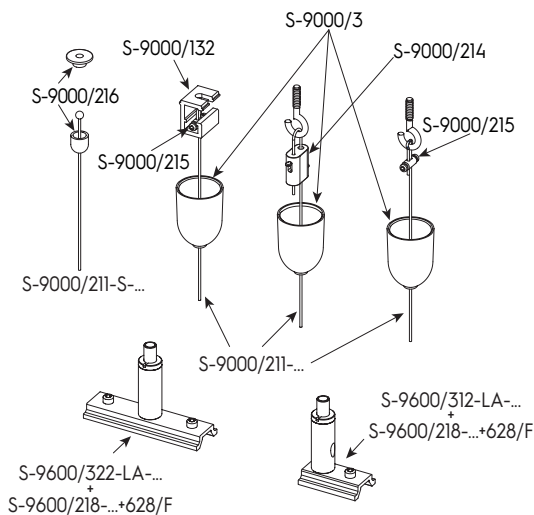

4 - 9601-S/B

End use

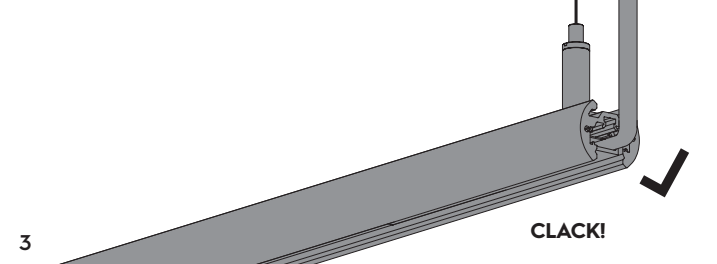
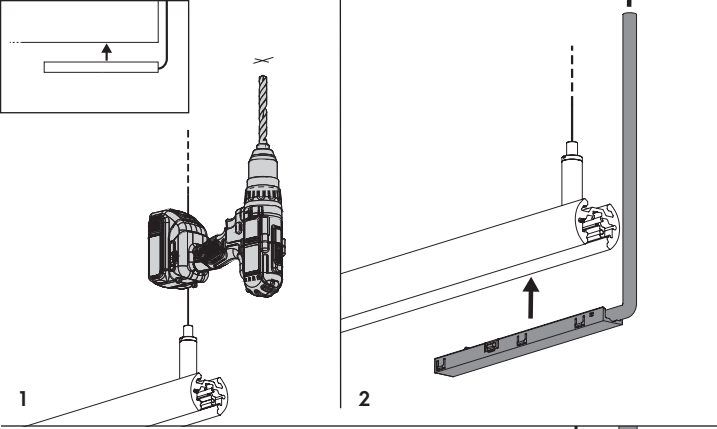

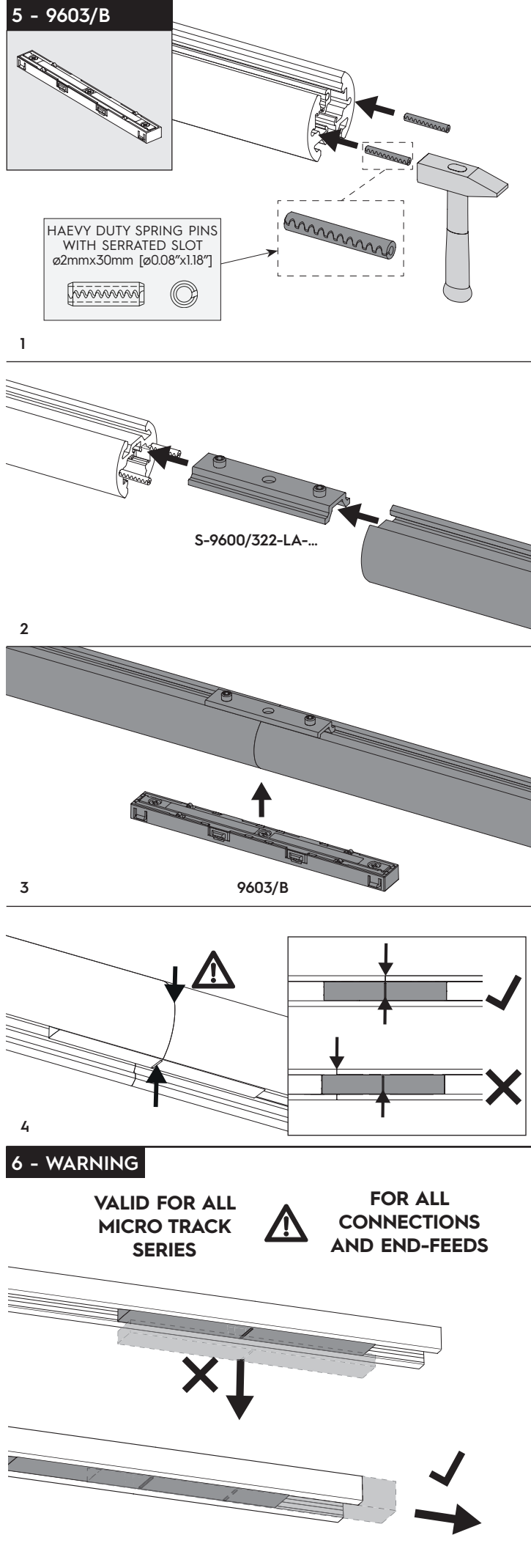
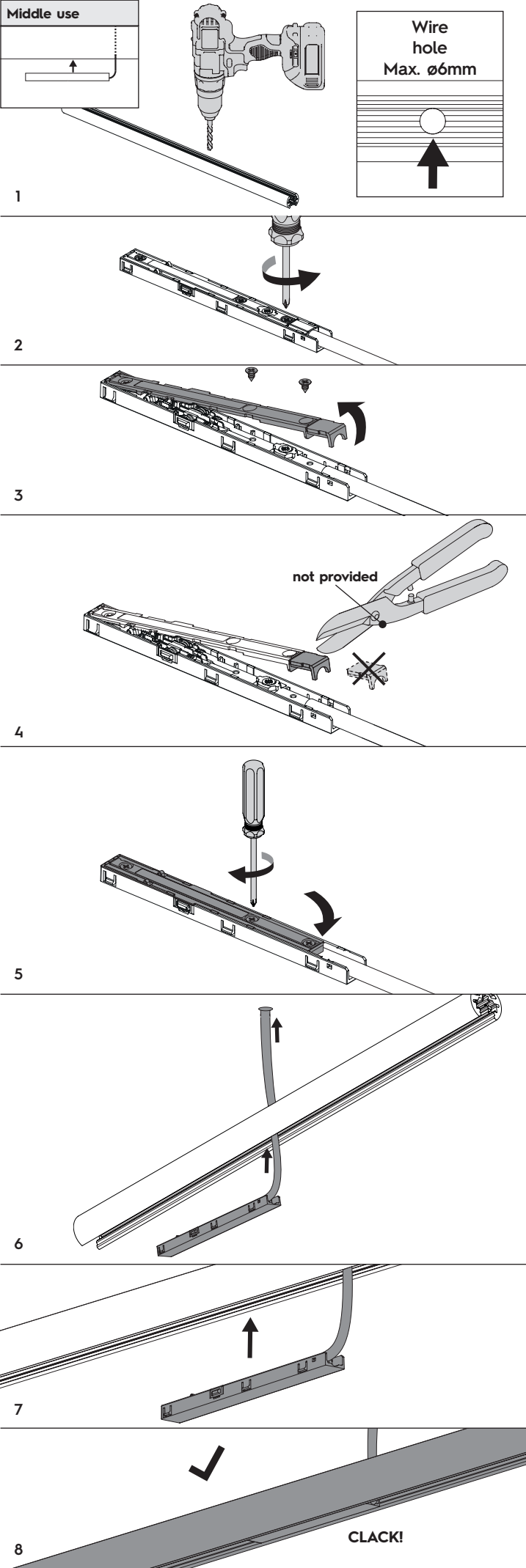

7 - CUTTING

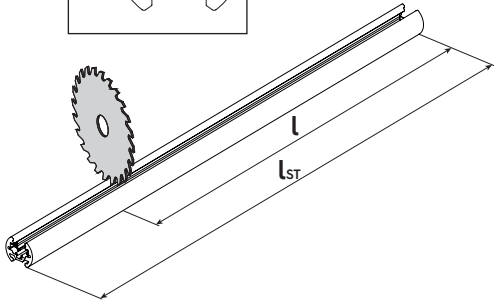
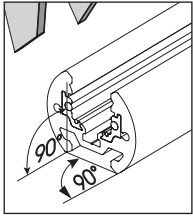
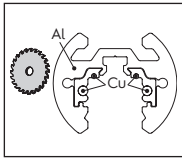

1

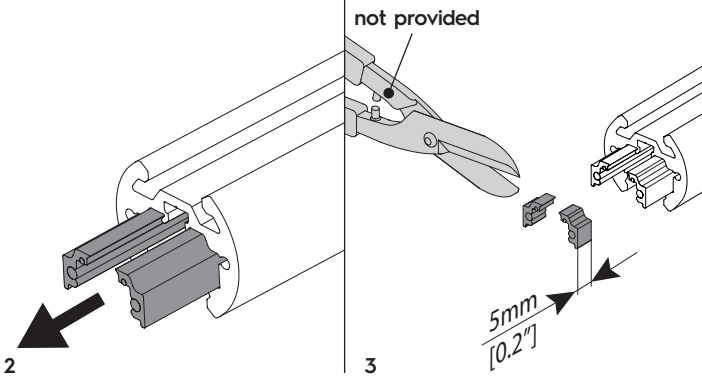

2

3

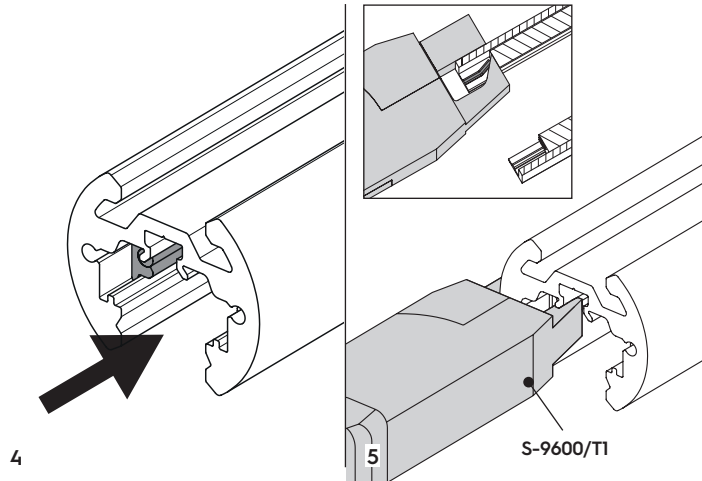



4

5

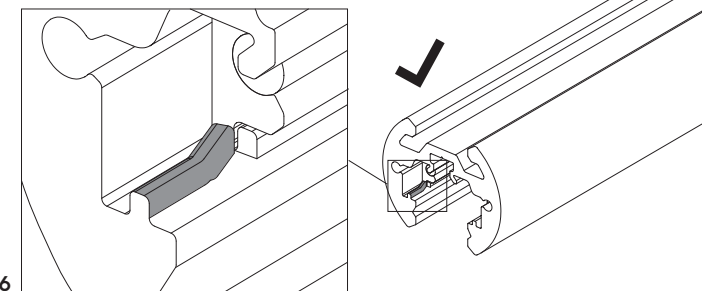
S-9600/T1



6

PLEASE ENSURE THAT THE DATA BUS WIRING DOES NOT CREATE A RING STRUCTURE. A FAILURE-FREE DATA BUS CANNOT BE ENSURED IF ONE IS PRESENT.

IF THE TRACK INSTALLATION REQUIRES THE USE OF "L", "T" OR "X" -SHAPED JOINT, IT IS POSSIBLE TO DISCONNECT THE DATA BUS IN THESE JOINTS TO AVOID CREATING A RING STRUCTURES.

--- Bus Data

UP&DOWN LIGHT - COMPOSITION IDEAS

DOWN LIGHT

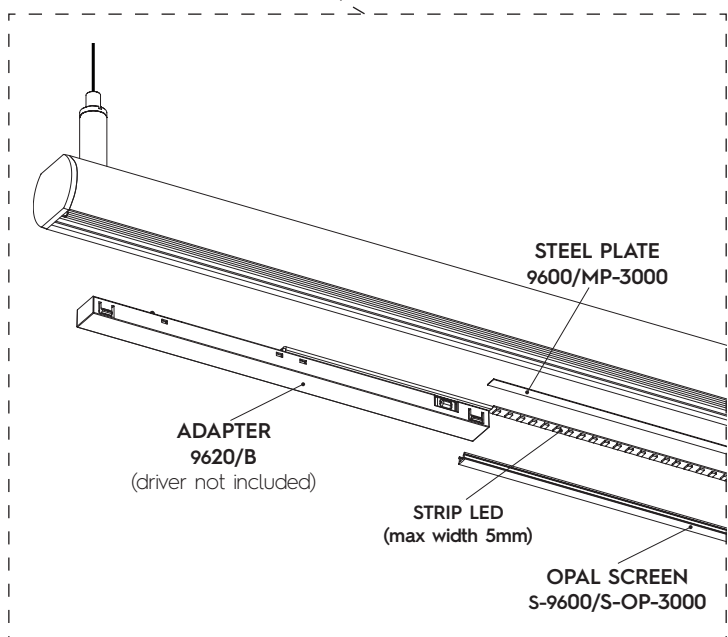
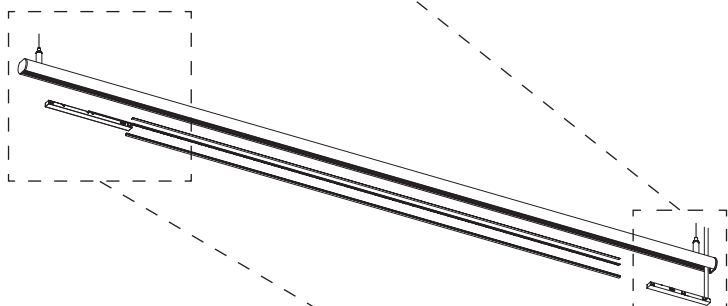
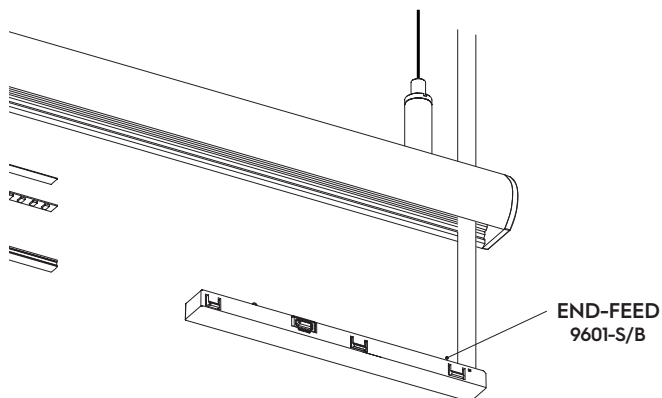
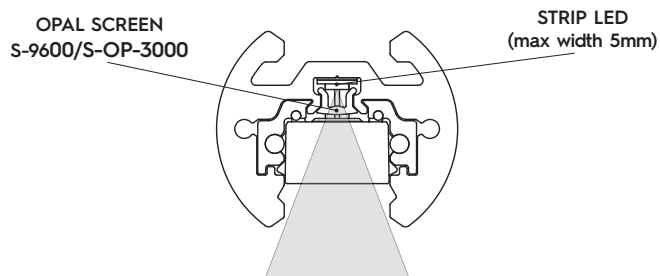

Questi prodotti non includono le certificazioni ENEC e cULus. Questi marchi riguardano solo i binari, senza strip led.

Nel momento in cui una strip led viene inserita in un prodotto finito chi compie questa operazione diventa il produttore del prodotto finito ed è quindi responsabile di dimostrare che il prodotto rispetta i requisiti delle direttive LVD, EMC, Eco Design e RoHS. Sono necessarie alcune certificazioni aggiuntive prima che il prodotto possa essere venduto.

UP LIGHT

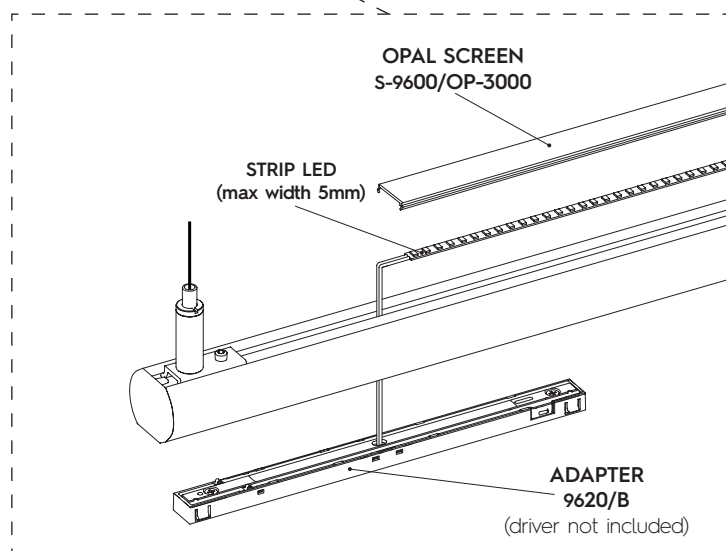
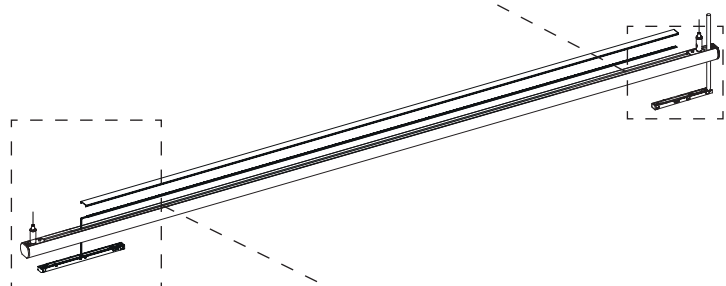
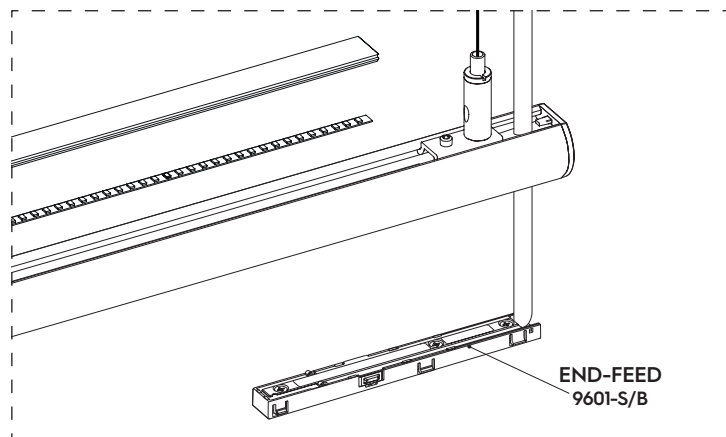
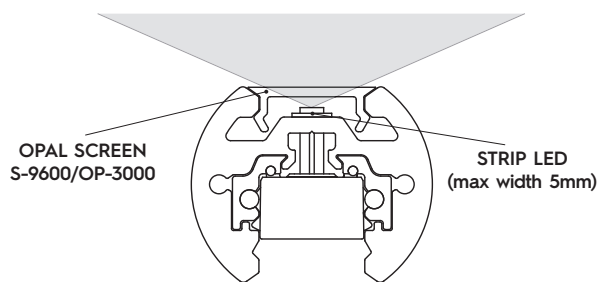

Please note that ENEC and cULus marks do not include these solutions. These marks cover only the track system without strip led.

When one integrates a strip led into an end product, one becomes the manufacturer of the final product and is therefore responsible for demonstrating compliance of the final product with the essential requirements of the LVD Directive, EMC Directive, Eco-design Directive, RoHS Directive. Some additional certification processes are required before the product can be sold.