

# ST5-E

# MULTISYSTEM evo

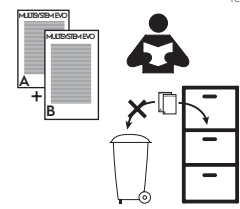

### 1 - 9500-.../...ST5-E

### 2 - USE

Trimless

CODE	L mm [ft]
9500-1/-...ST5-E	1000 [3.28']
9500-2/-...ST5-E	2000 [3.28']
9500-3/-...ST5-E	3000 [3.28']

### 3 - TRIMLESS FIXING

>250	500	500
[0.82']	[1.64']	[1.64']

#### MAX LOAD

### 2

### 3

### 3a with S-9000/118...

### 3b with S-9000-P2/117

### 5

### 6

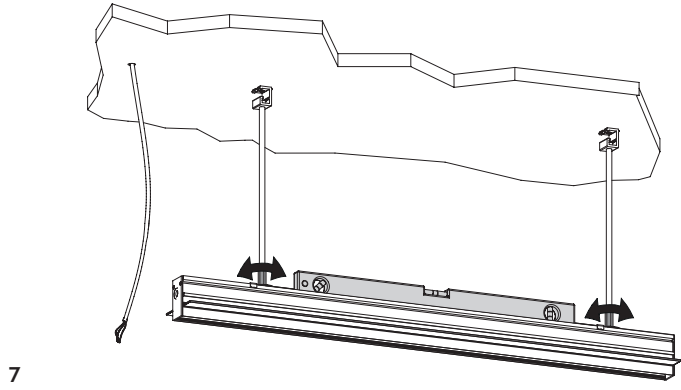

7

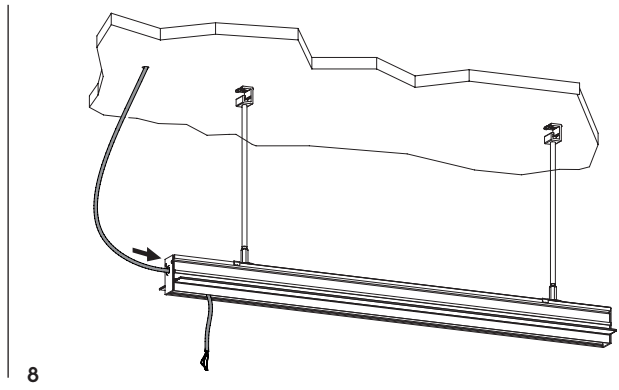

8

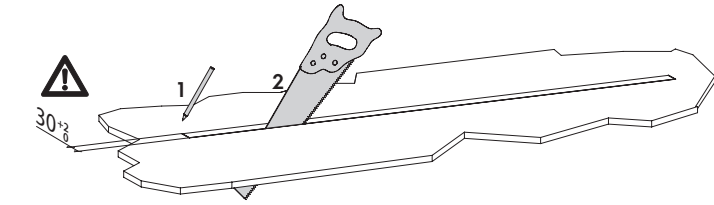

9

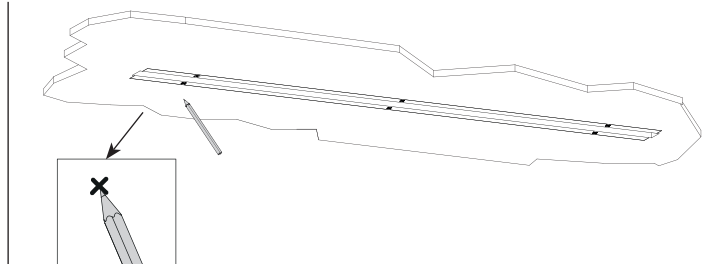

10

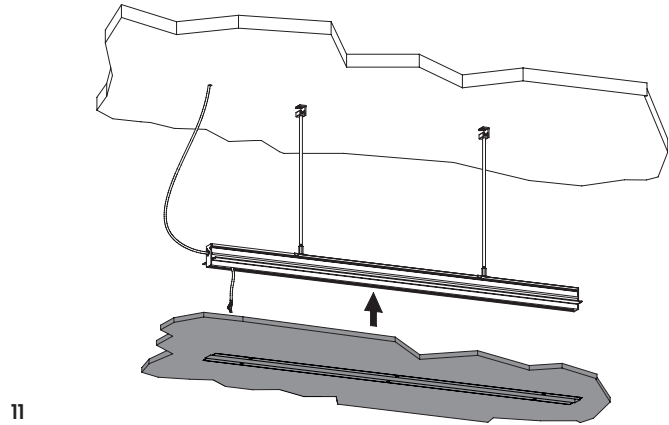

11

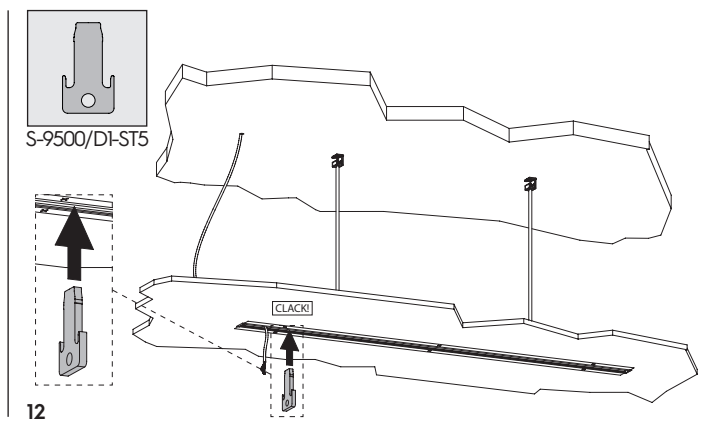

12

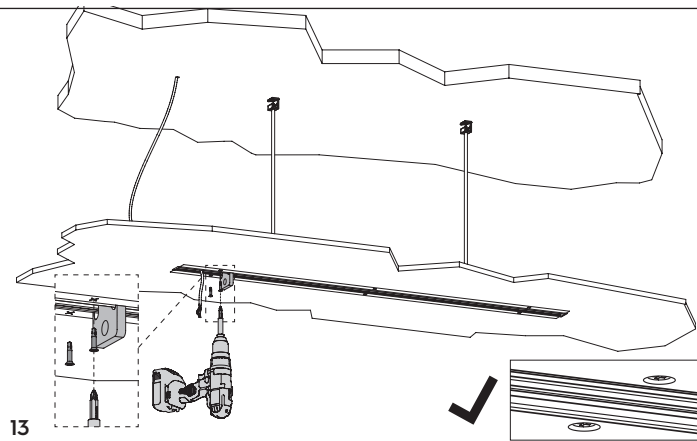

13

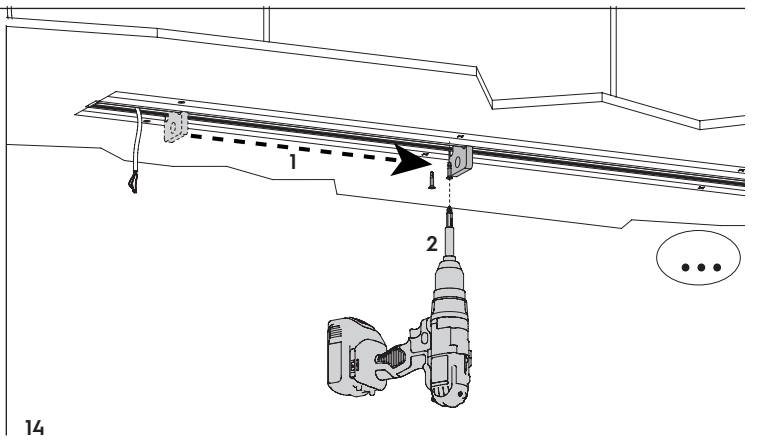

14

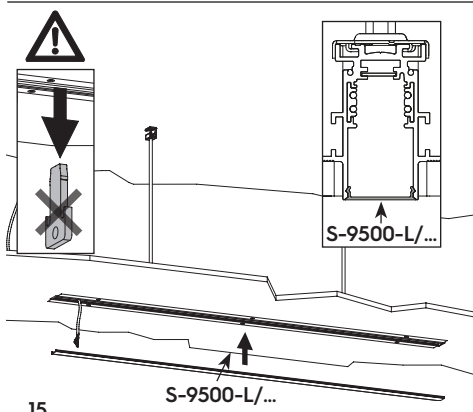

15

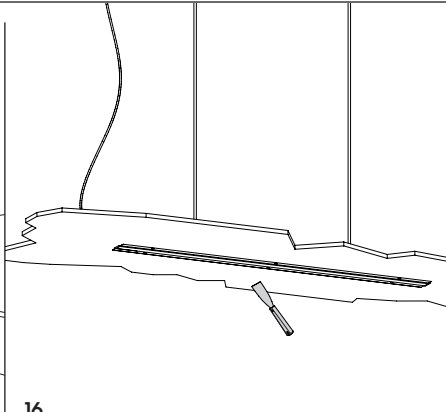

16

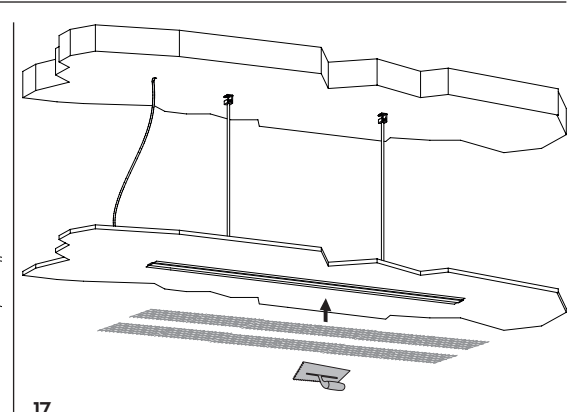

17

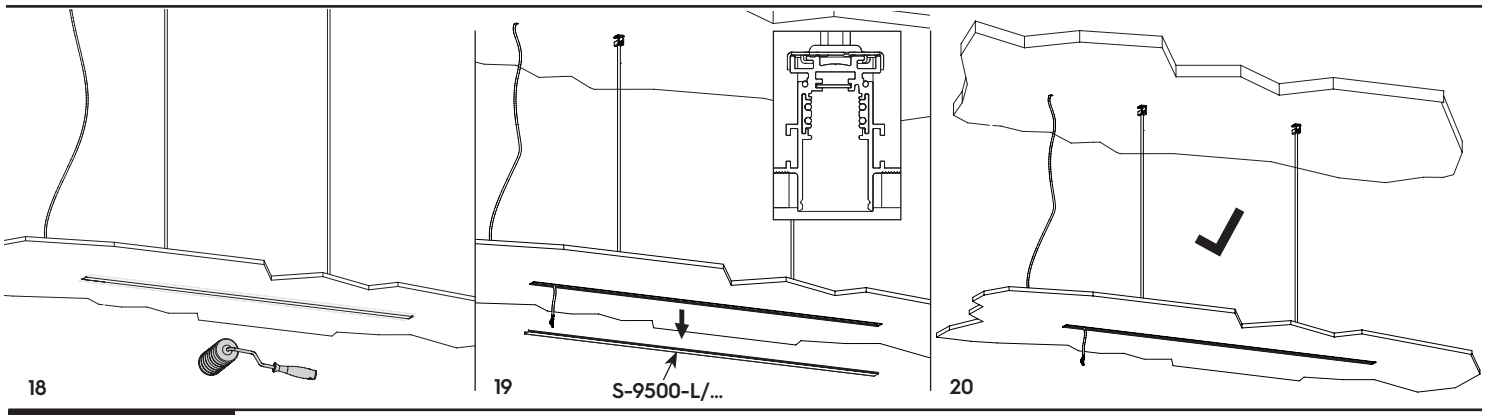

**4 - IN ROW USE**

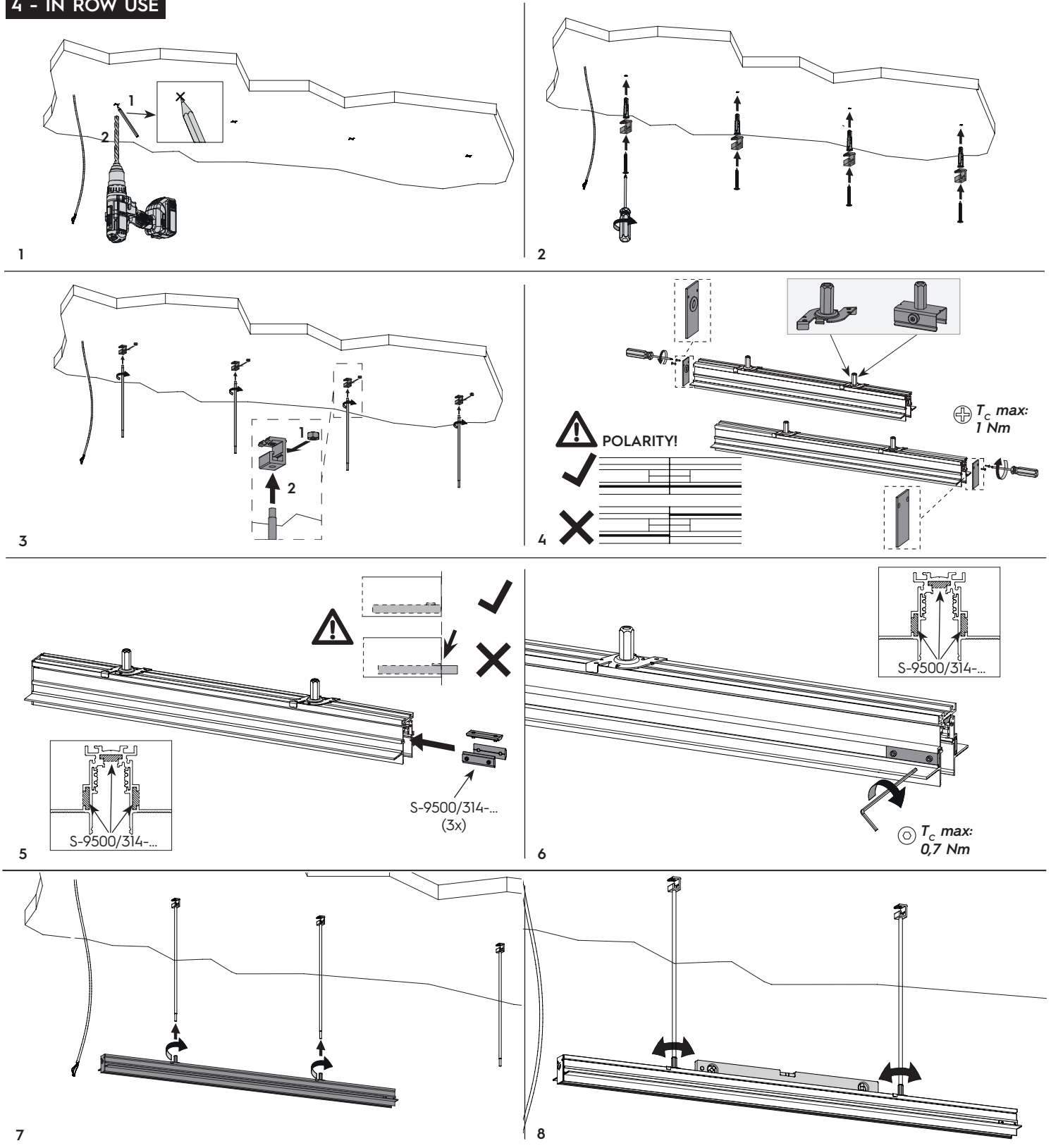

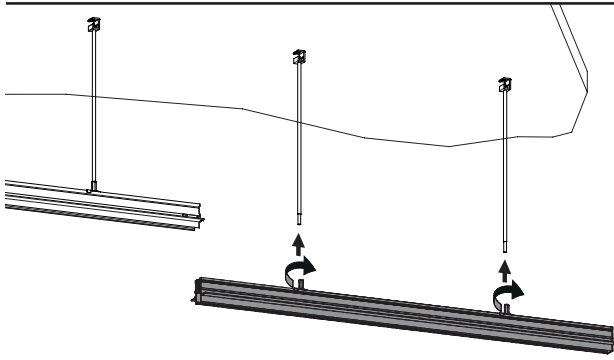

9

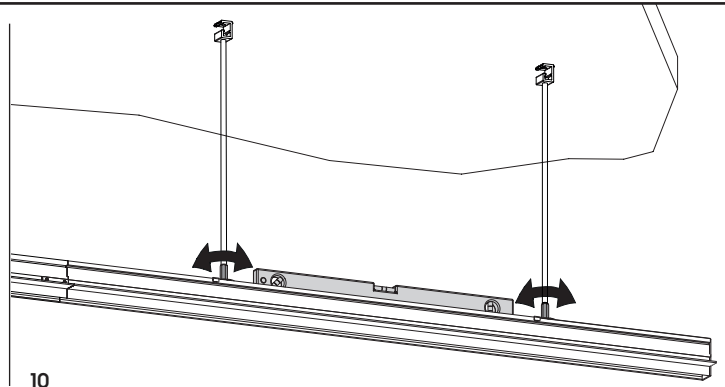

10

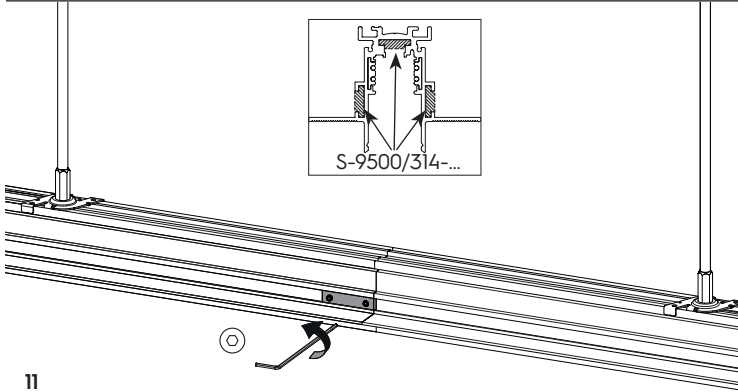

11

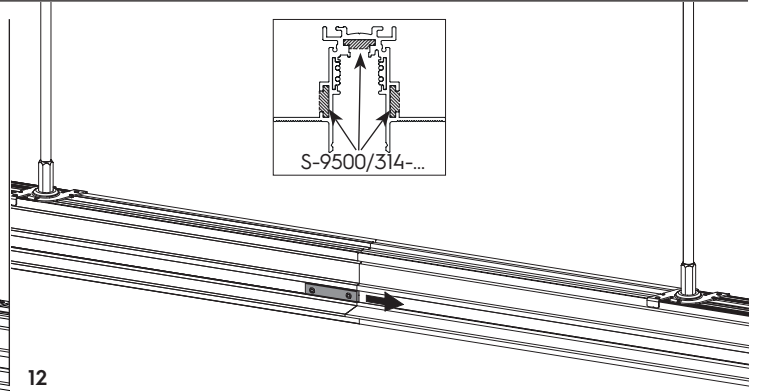

12

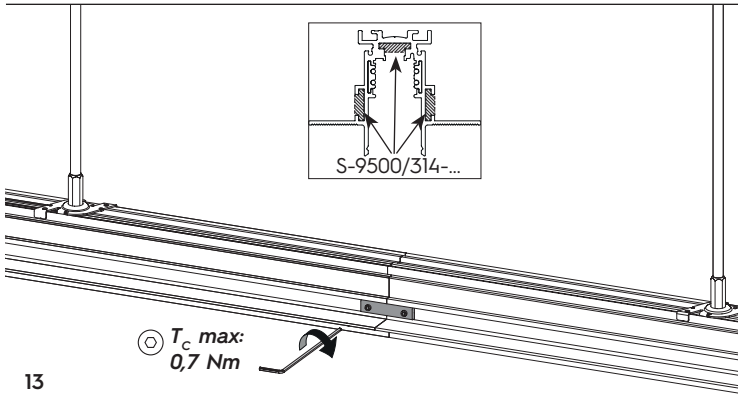

13

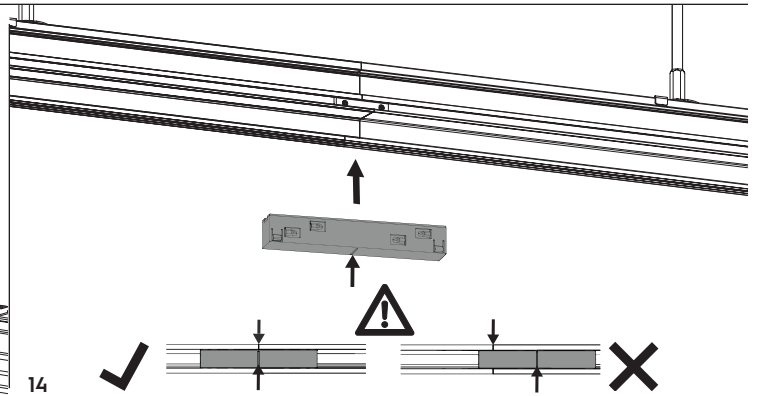

14

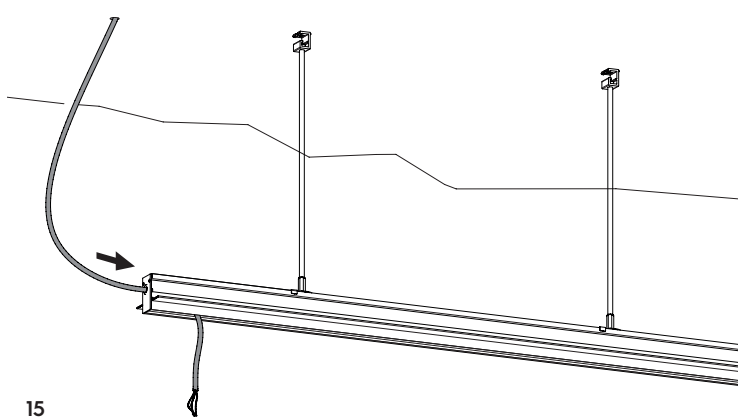

15

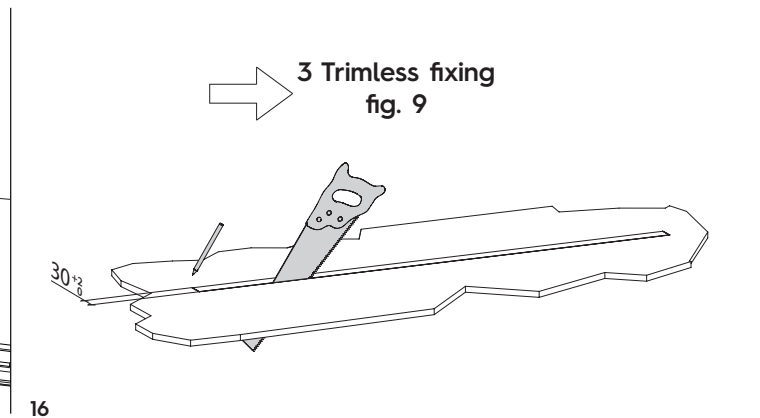

16



# 8 - CUTTING

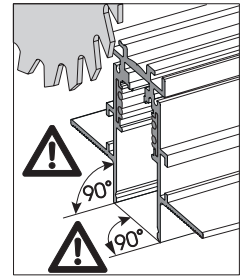
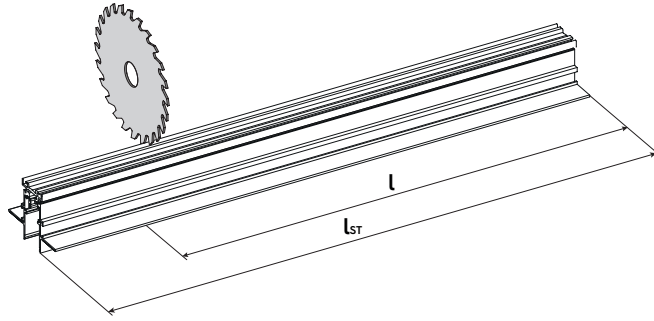
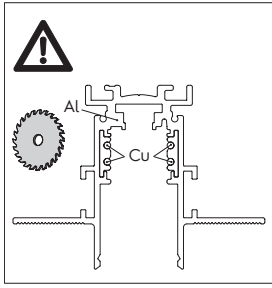

1

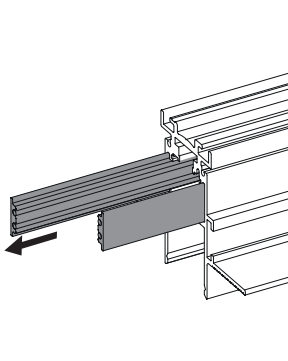

2

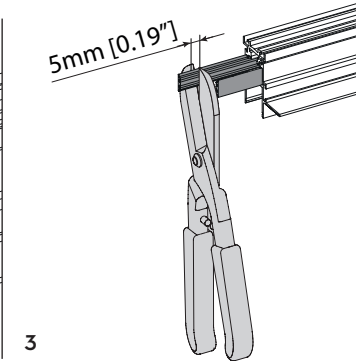

3

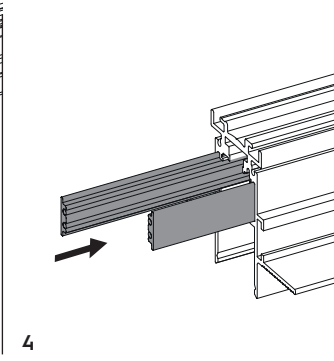

4

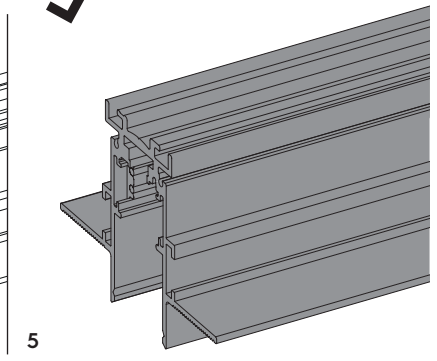

5

## 5 - S-9511/...-ST5

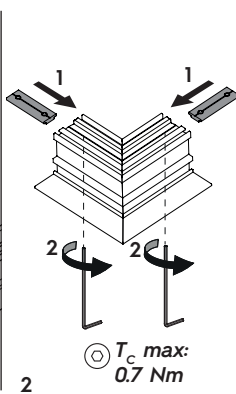
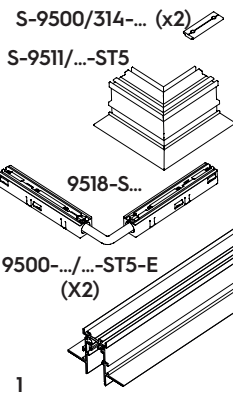
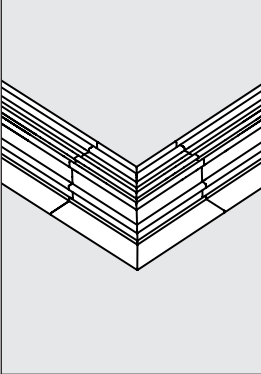

2

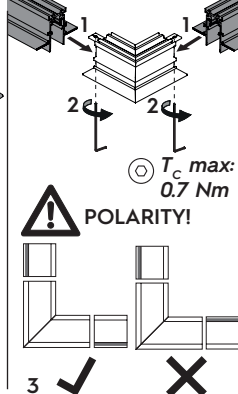

3

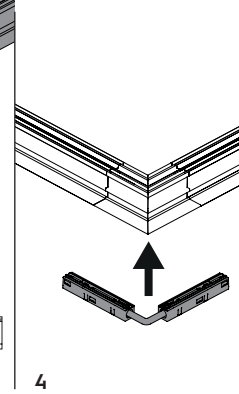

4

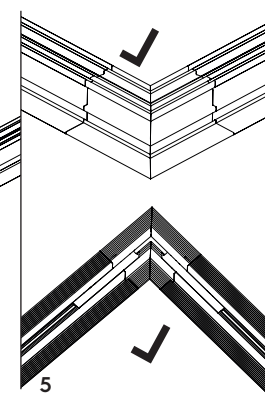

5

## 6 - S-9511-E/...-ST5

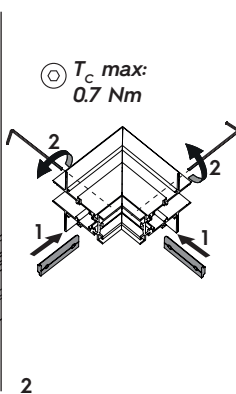
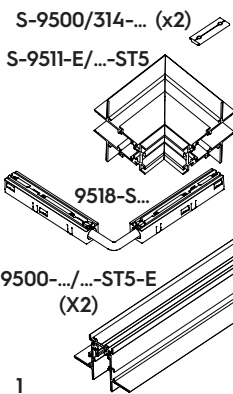
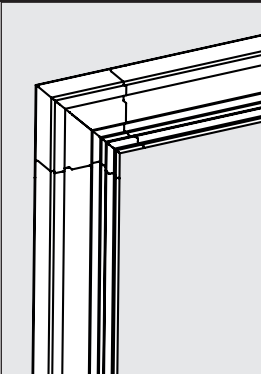

2

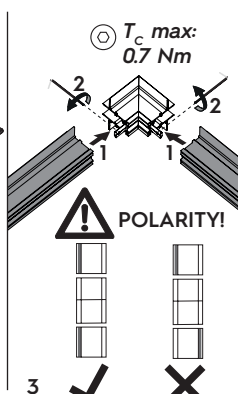

3

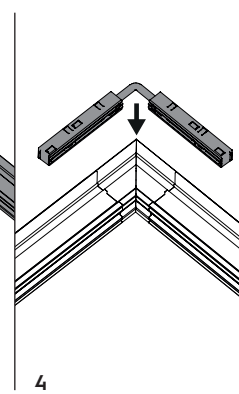

4

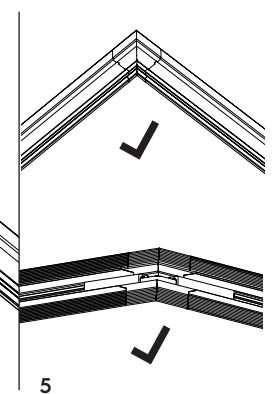

5

## 7 - S-9511-I/...-ST5

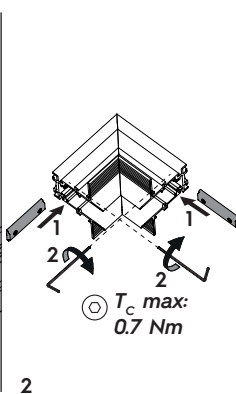
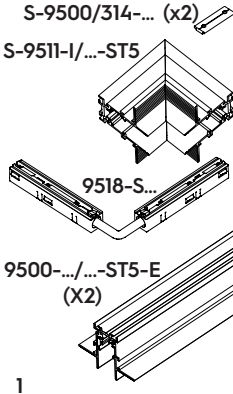
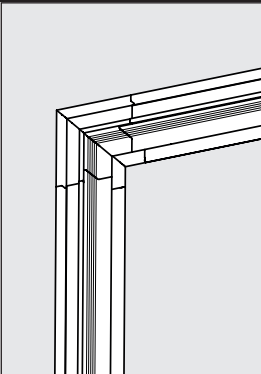

2

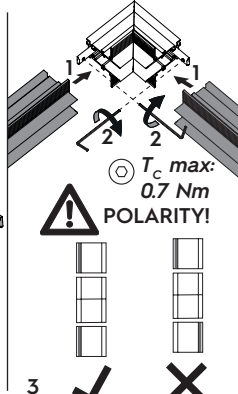

3

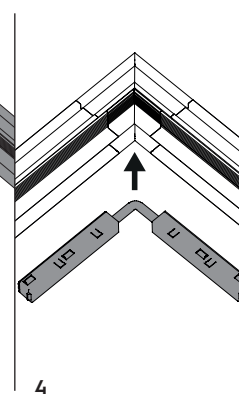

4

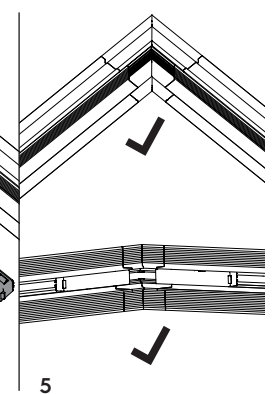

5

9 - 9501-S/...-E

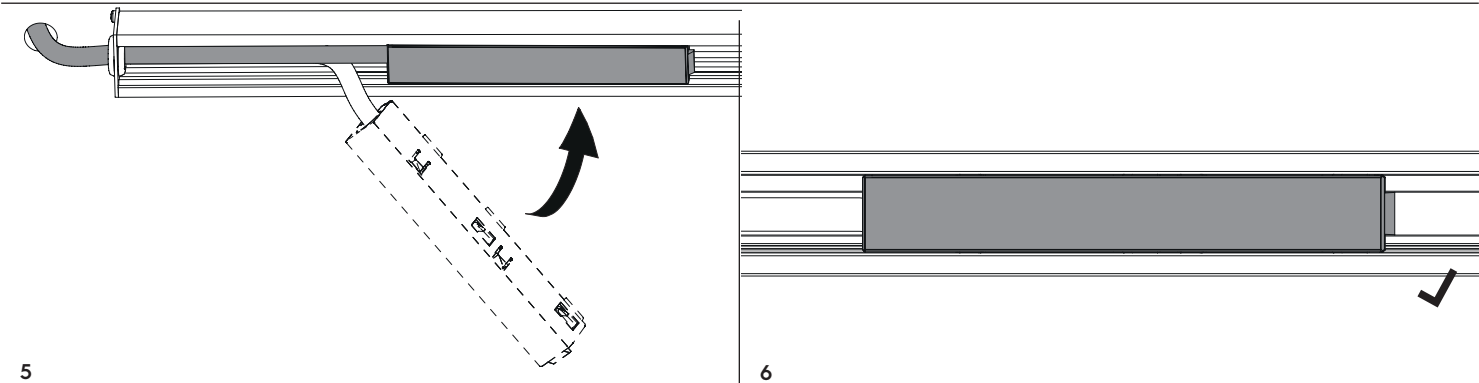
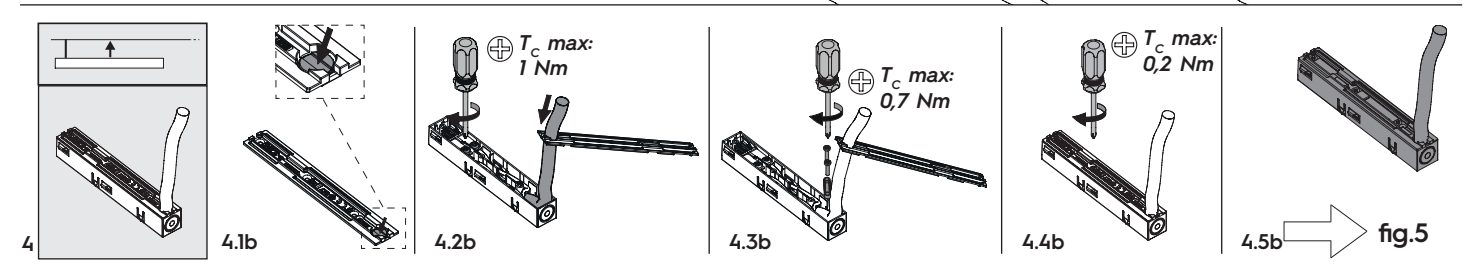
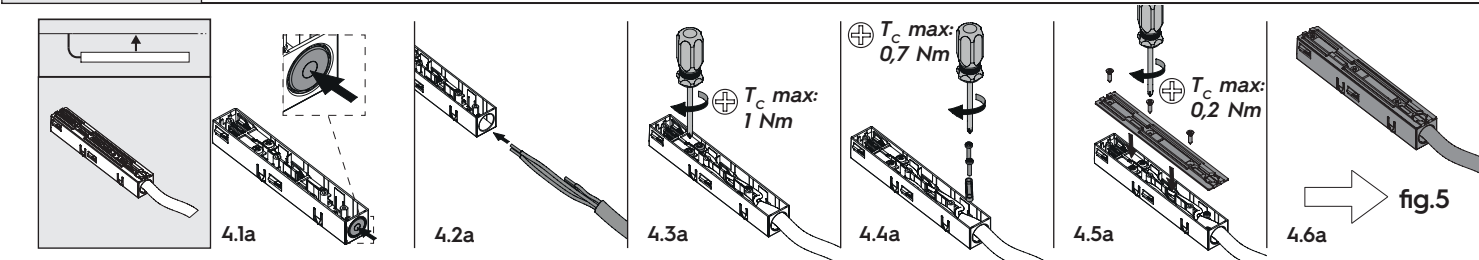
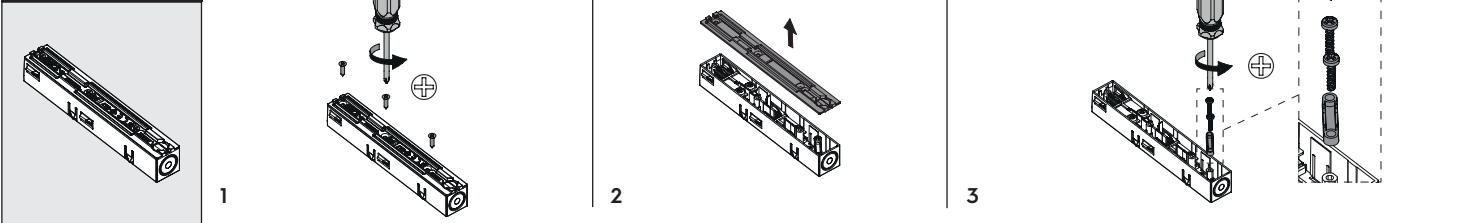

10 - 90° ANGLE

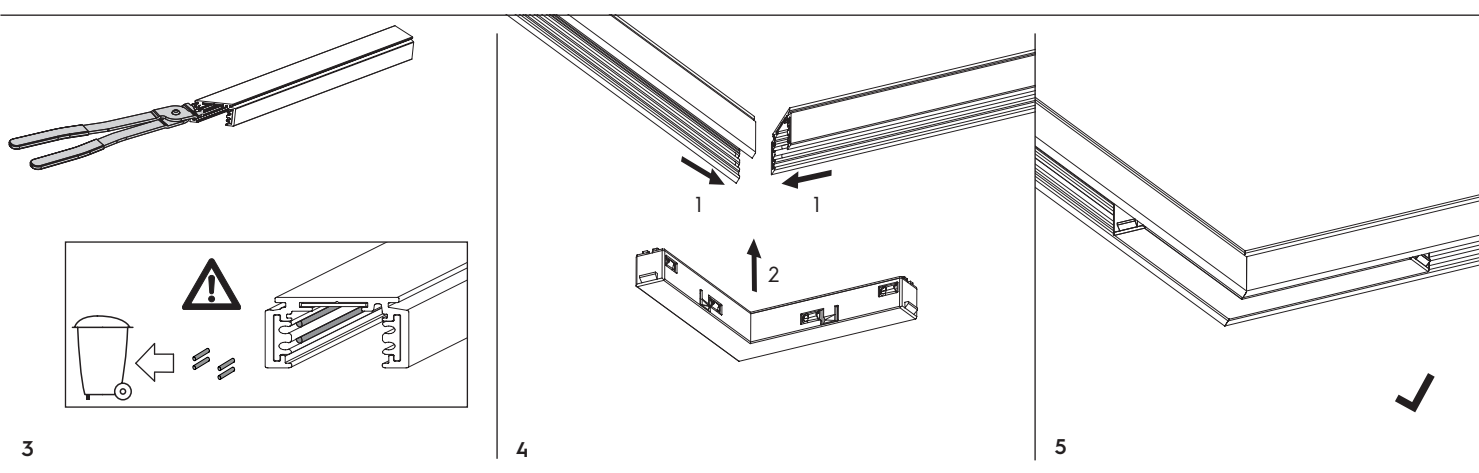
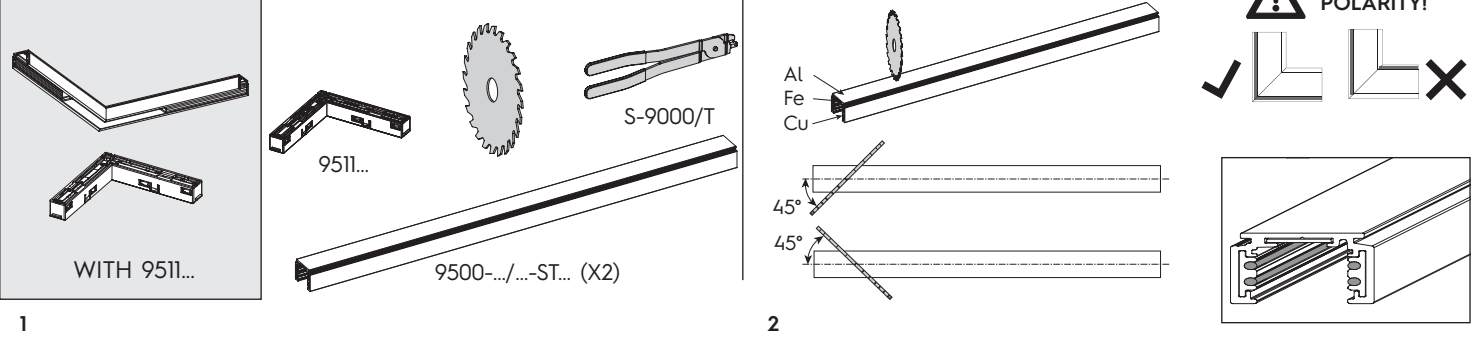

**11 - ≈ 90° ANGLE**

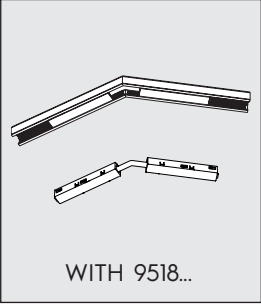

1

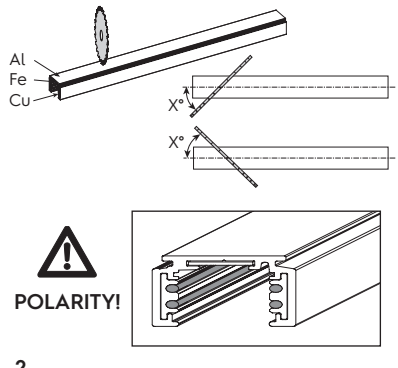
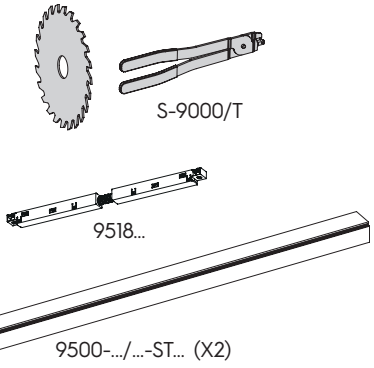

2

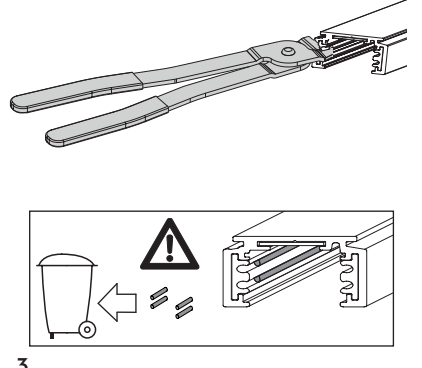

3

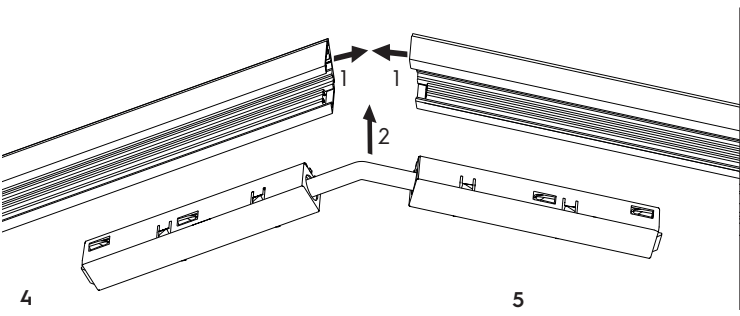

4

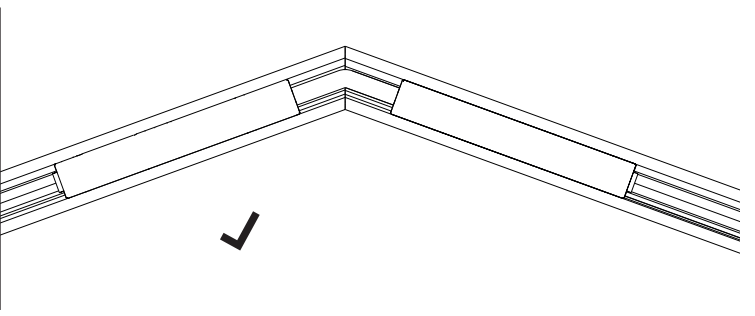

5

**12 - WALL CEILING 90° ANGLE**



1

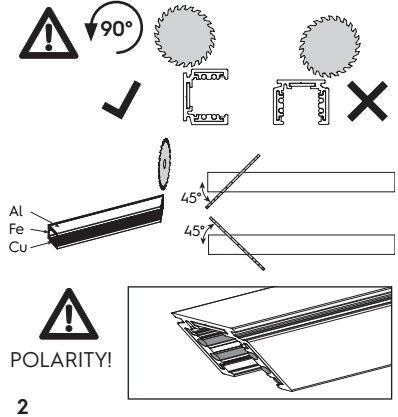
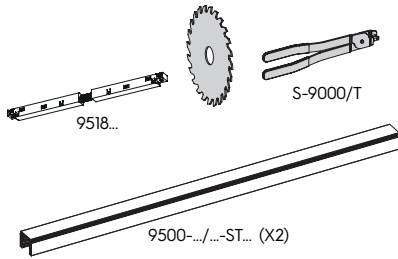

2

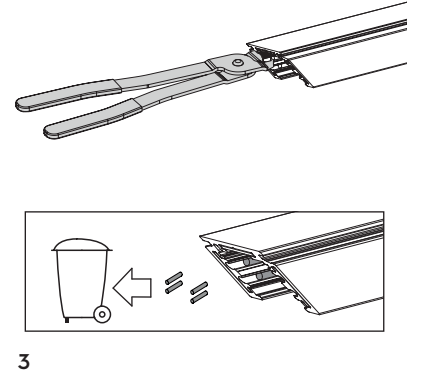

3

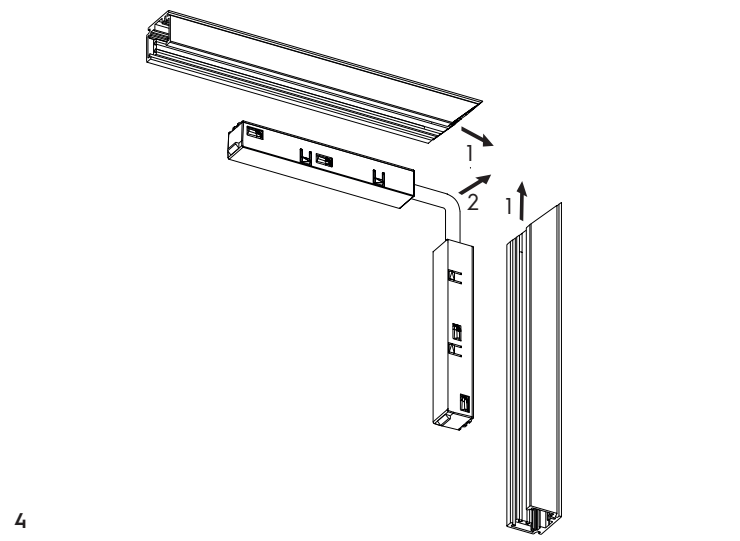

4

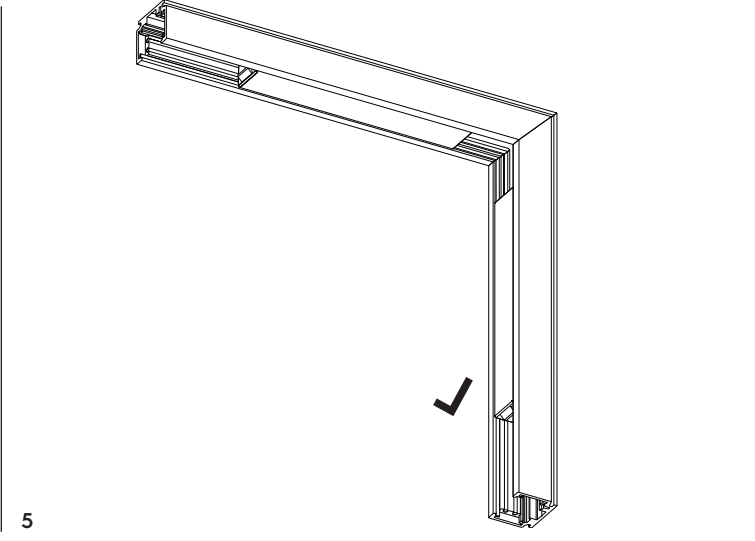

5