

ST18-E

MULTISYSTEM evo

1 - 9500-.../...ST18-E

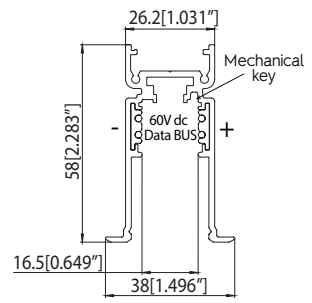
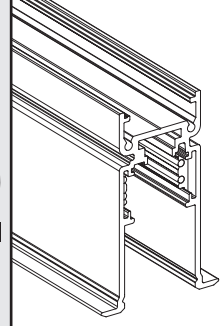
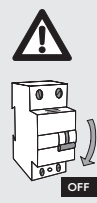

CODE	L mm [ft]	
9500-1/...-ST18-E	1000 [3.28']	
9500-2/...-ST18-E	2000 [3.28']	
9500-3/...-ST18-E	3000 [3.28']	

2 - USE

Recessed (ceiling)

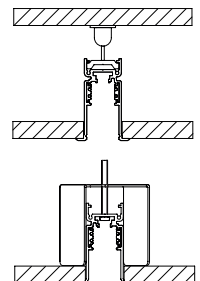

3 - RECESSED FIXING

3a with spring:

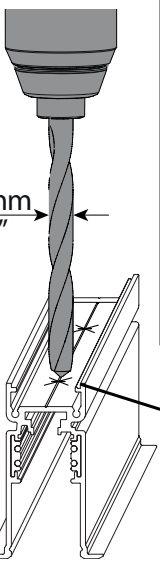
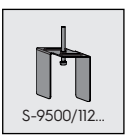

Ø 4.5mm
Ø 0.18"

MAX LOAD	
200 [0.66']	600 [1.97']
25 Kg	
200 [0.66']	300 [0.98']
36 Kg	
150 [0.49']	250 [0.82']
48 Kg	

Check drywall max load!

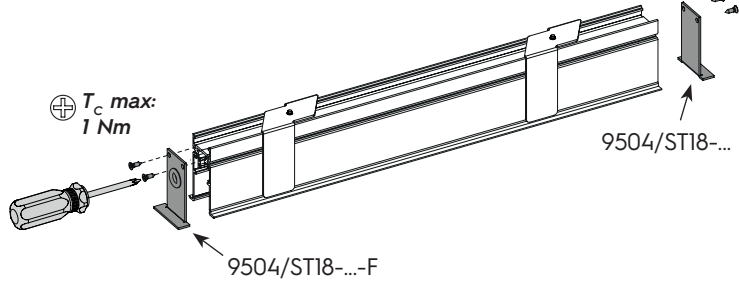
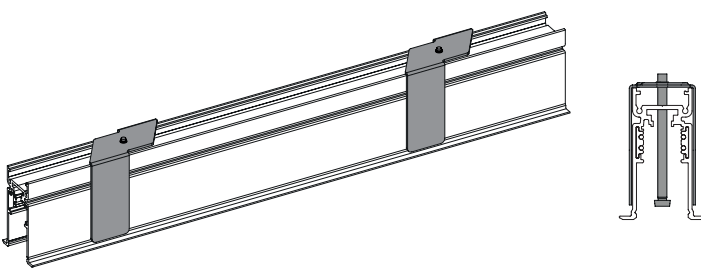
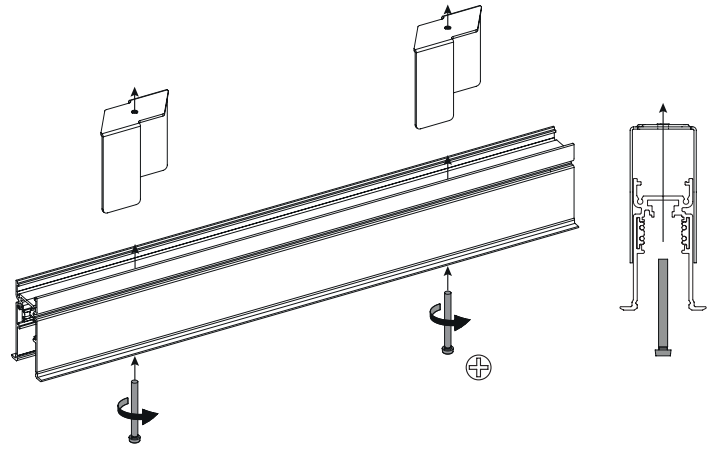
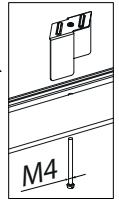

T_c max:
1 Nm

9504/ST18-...

9504/ST18-...-F

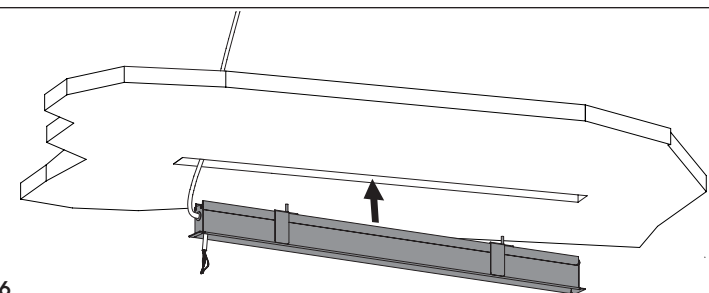
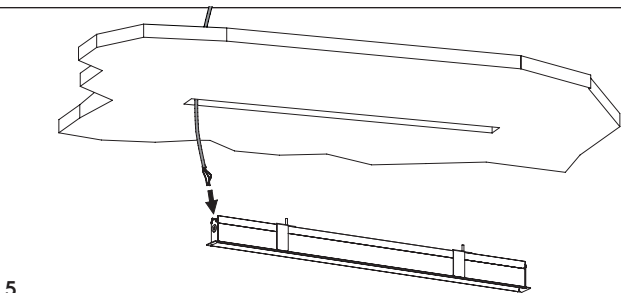

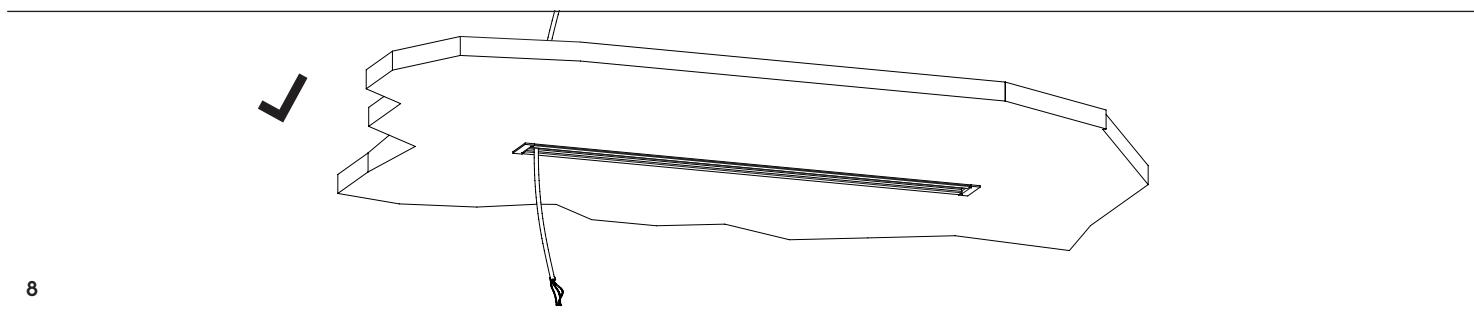
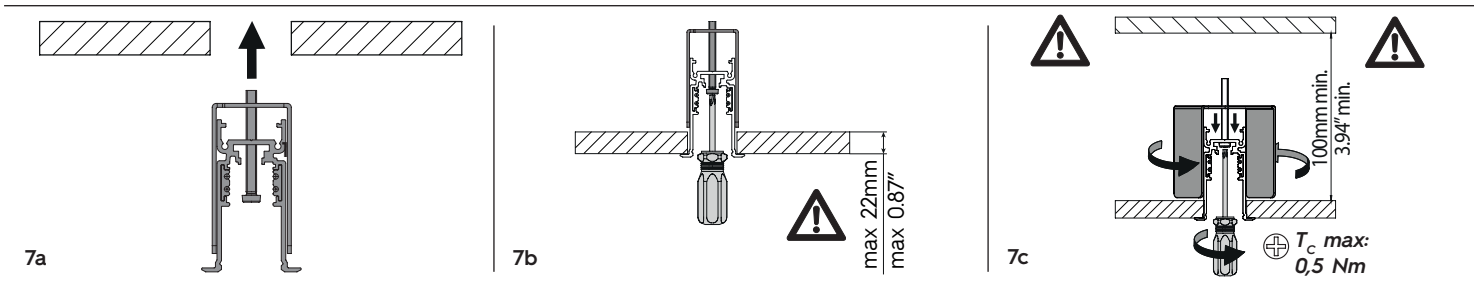

3b with rigid suspension sets

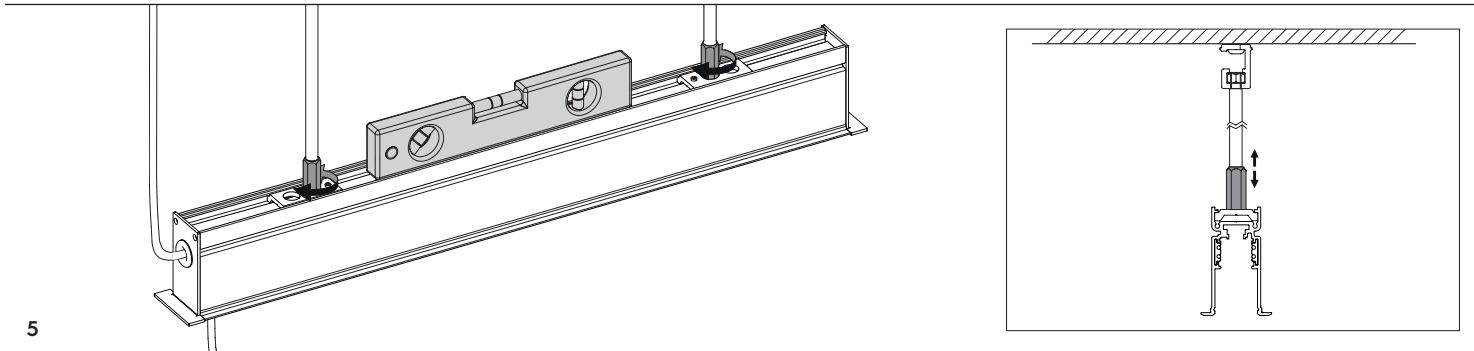
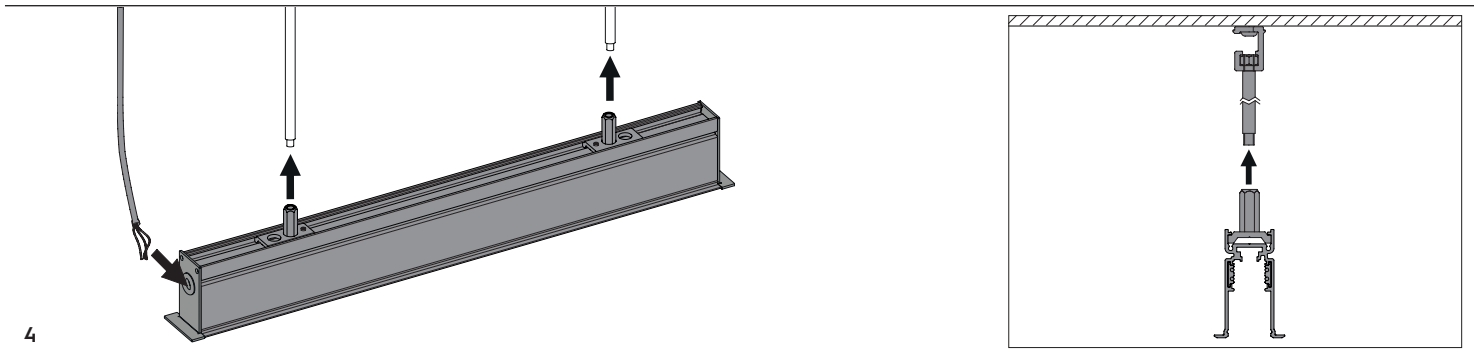
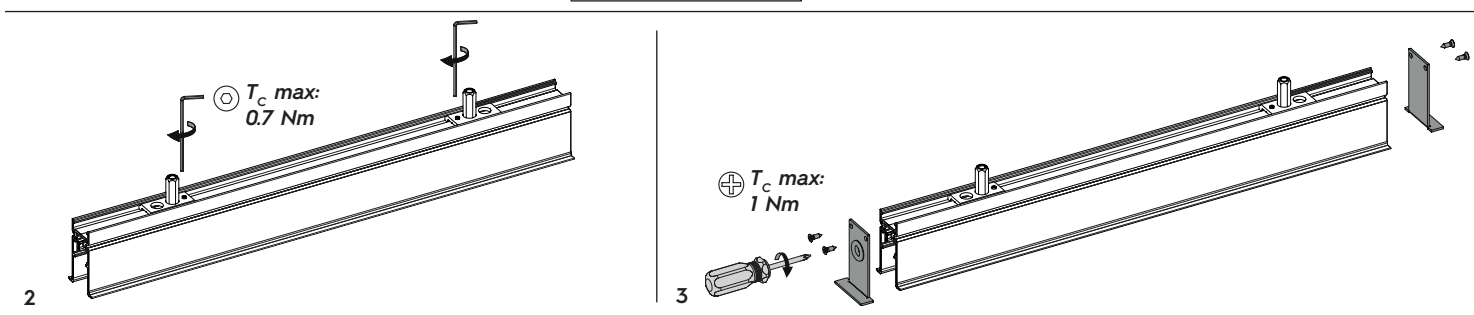
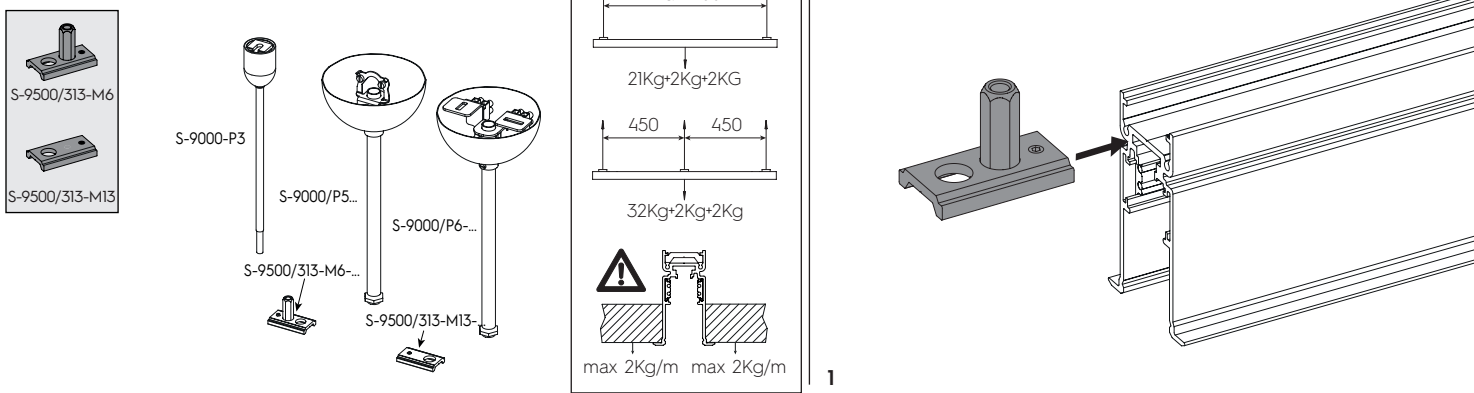

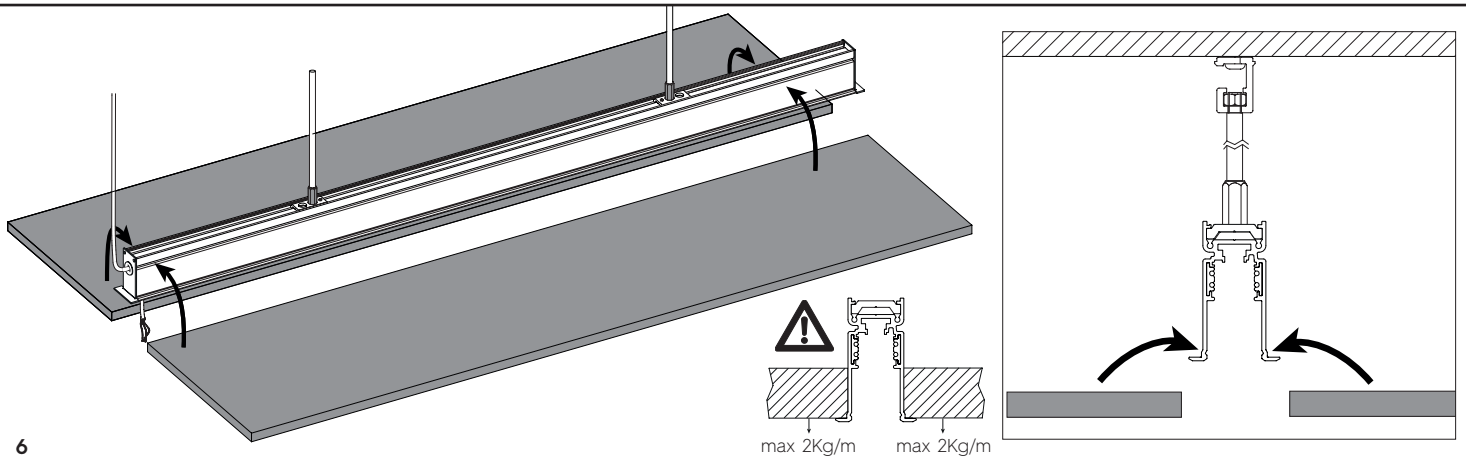

6

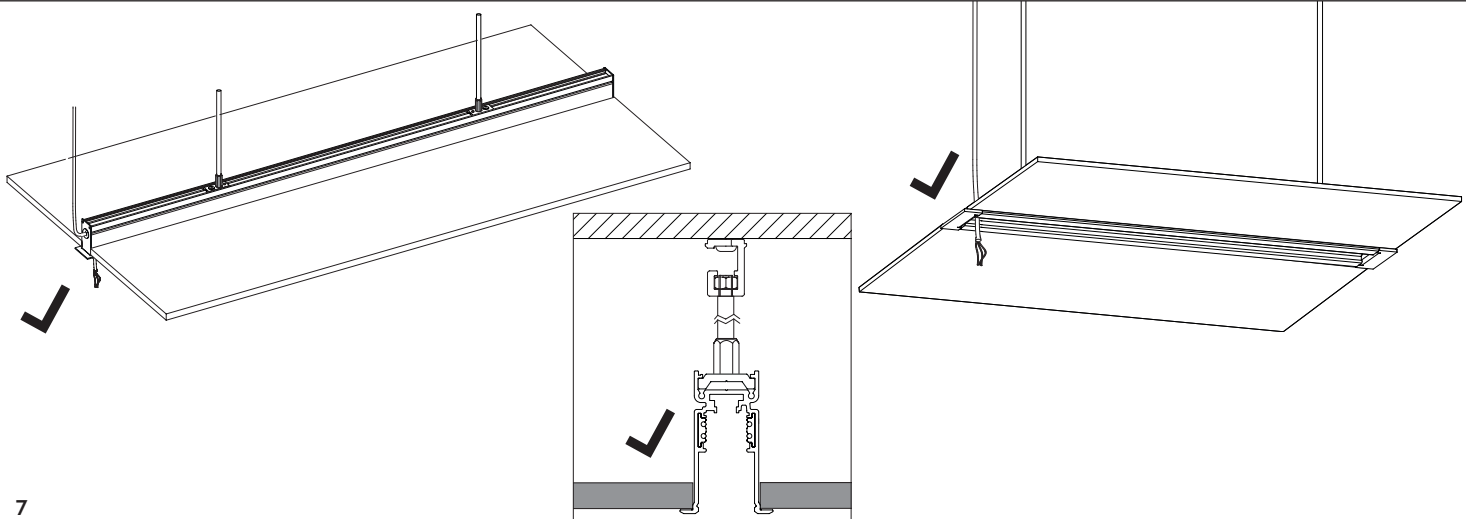

7

3c with brackets/clamps

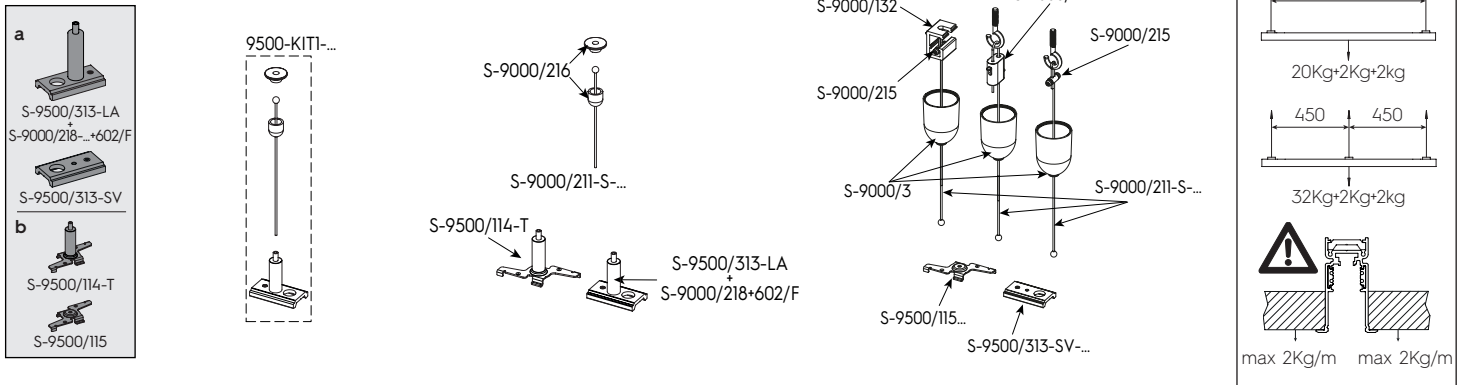

1a

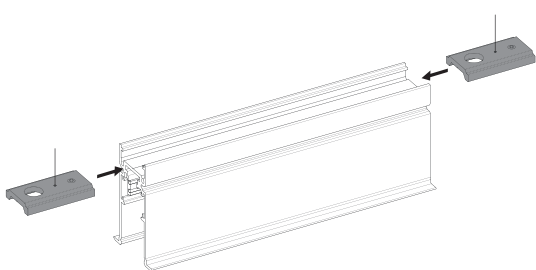

2a

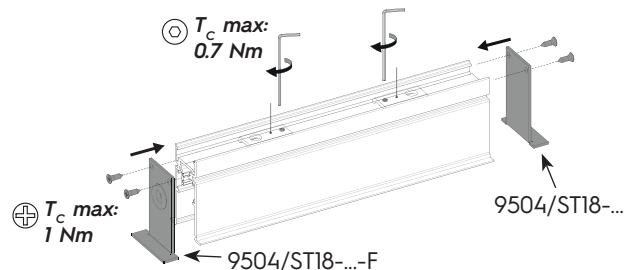

1b

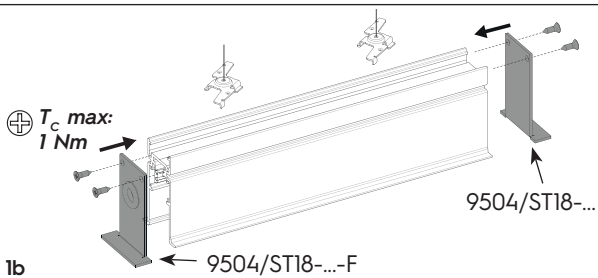

2b

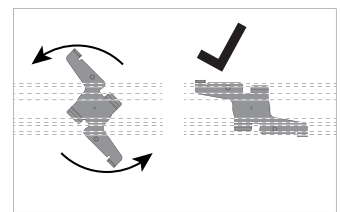
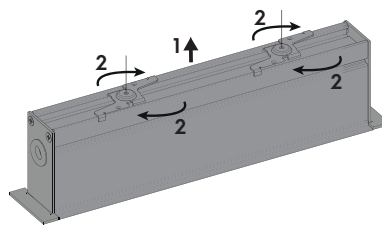

4 - IN ROW USE

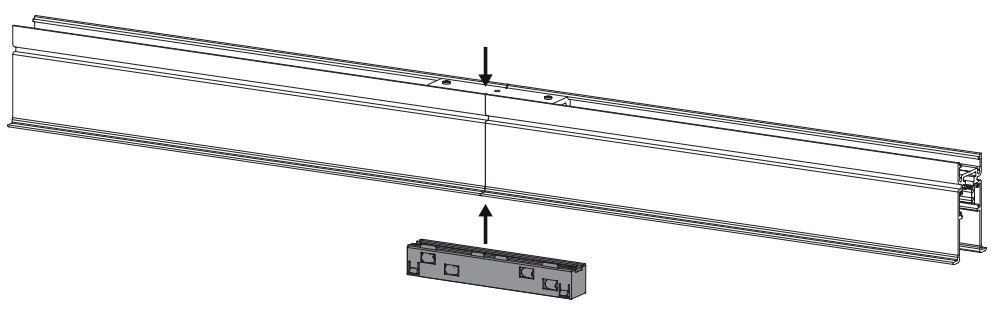
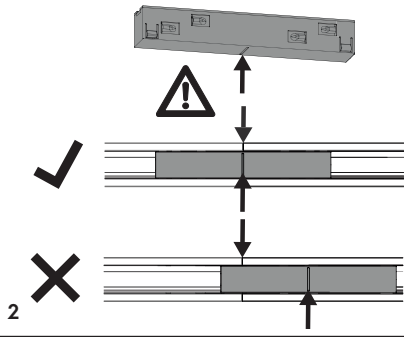
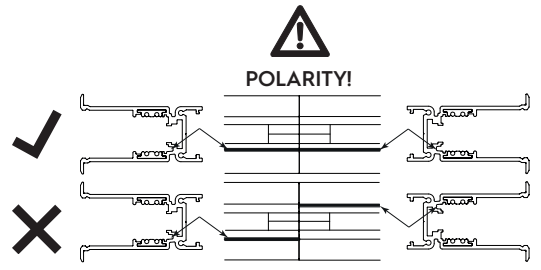
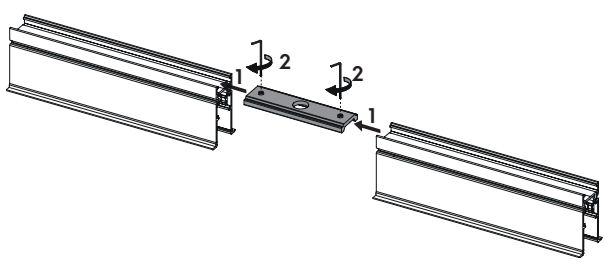
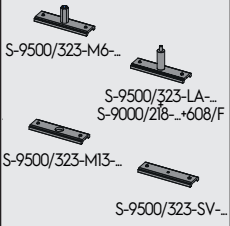

5 - S-9511/...-ST18-E

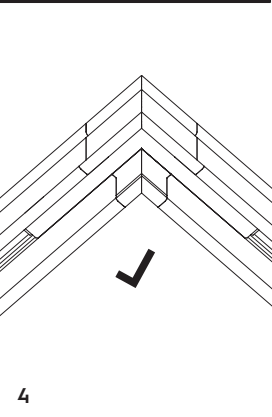
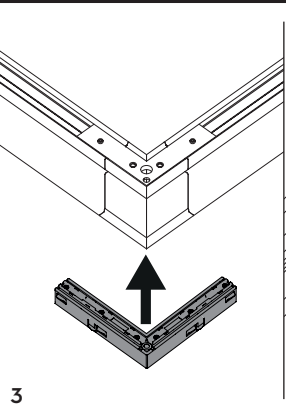
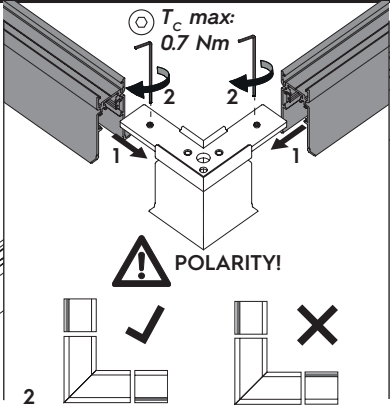
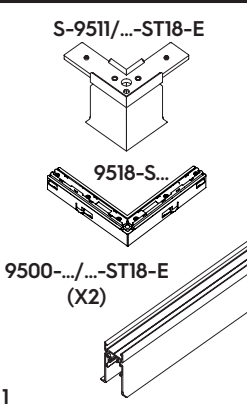
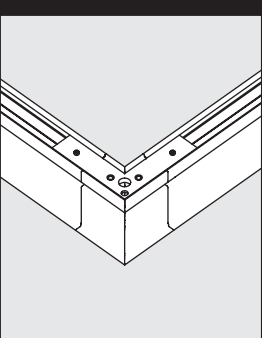

6 - CUTTING

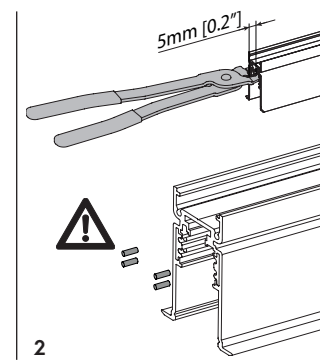
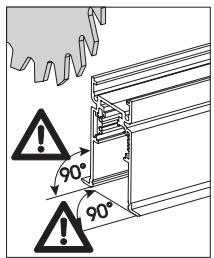
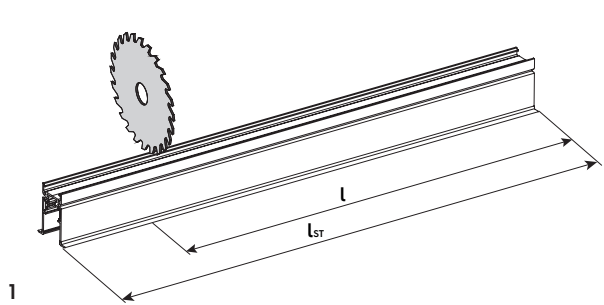
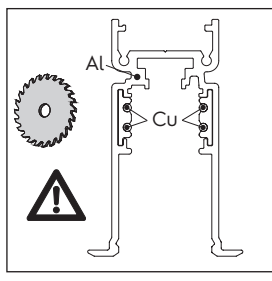

7 - 9501-S/...-E

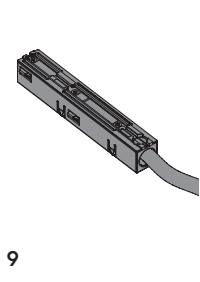
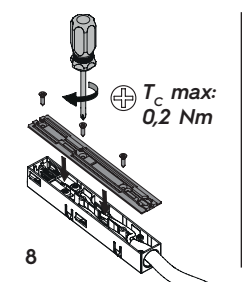
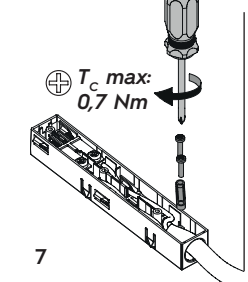
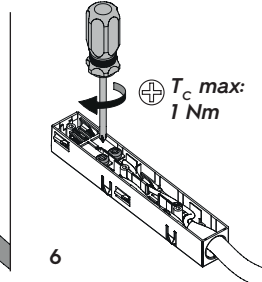
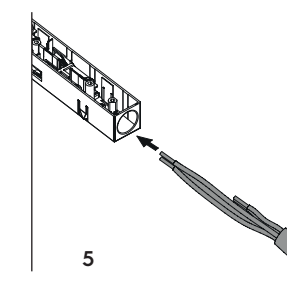
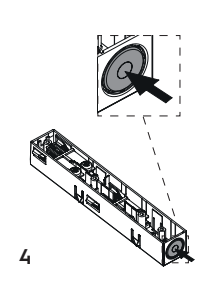
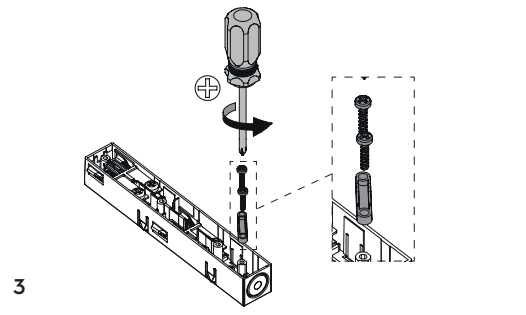
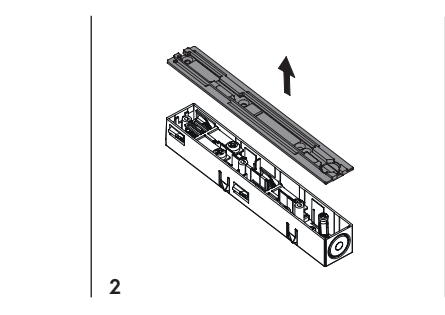
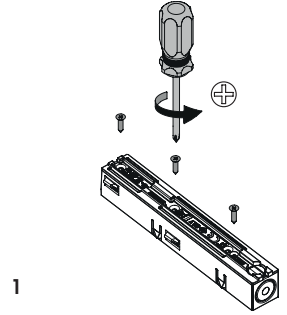
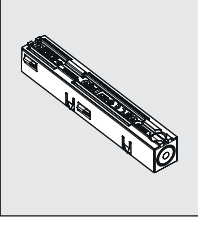

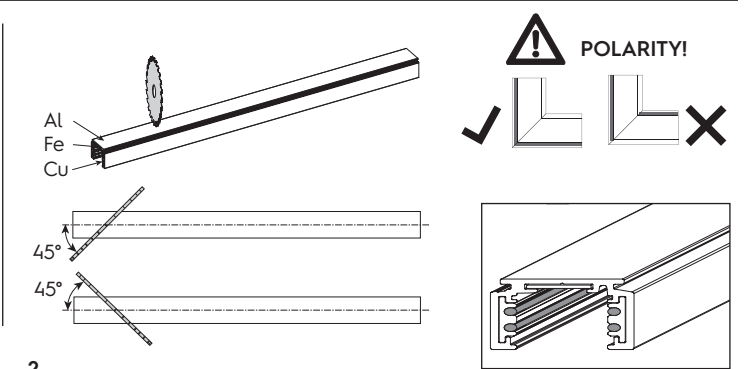
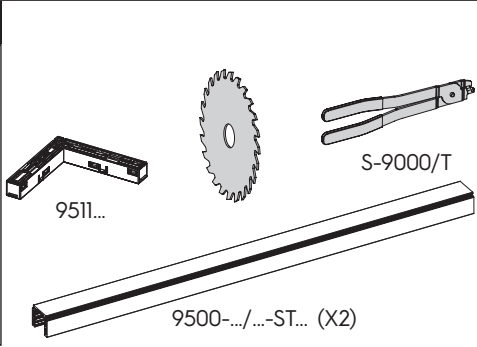
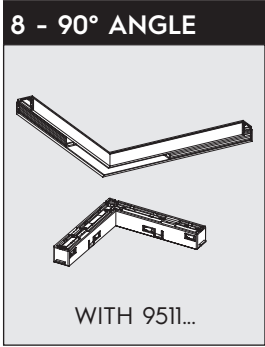
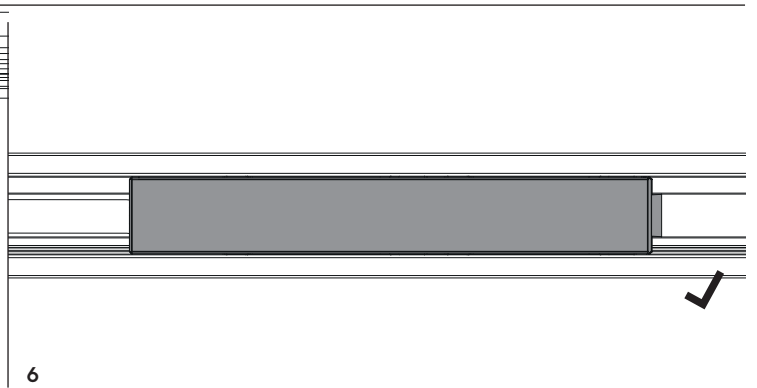
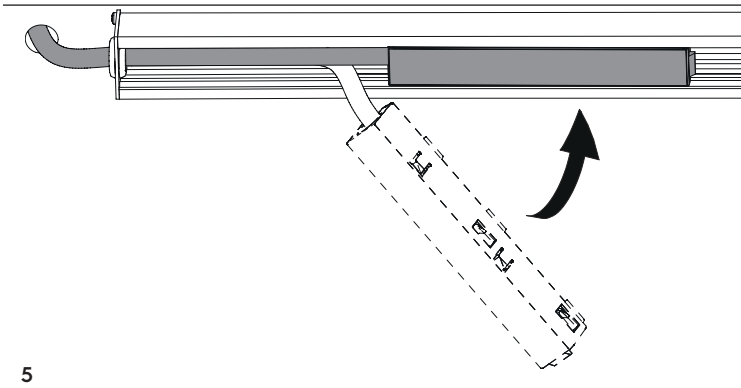

1

2

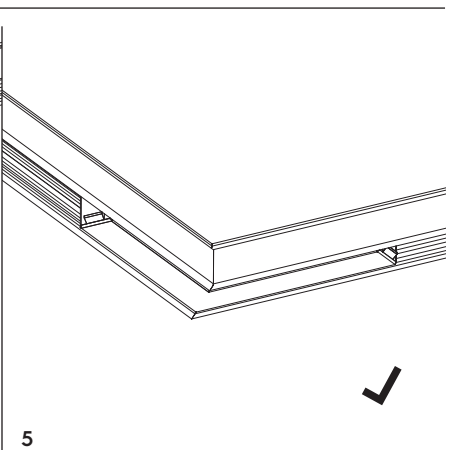
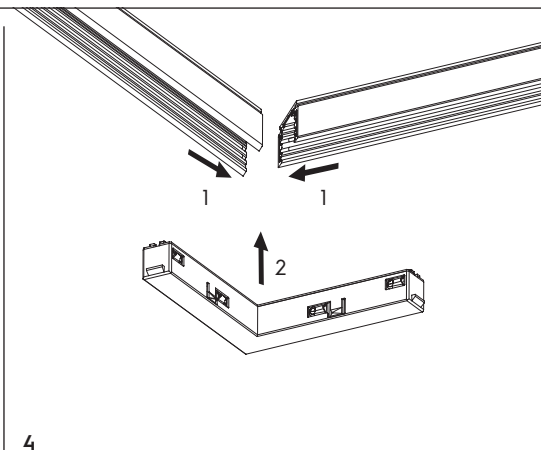
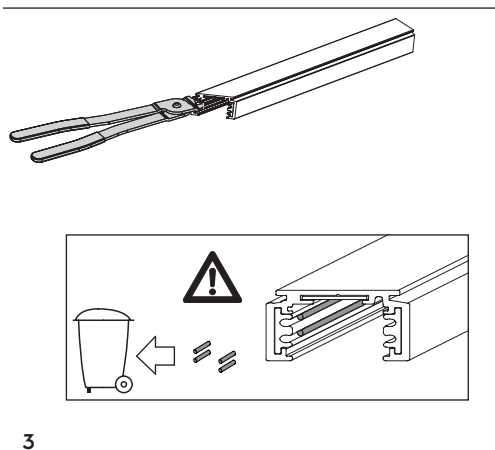

3

4

5

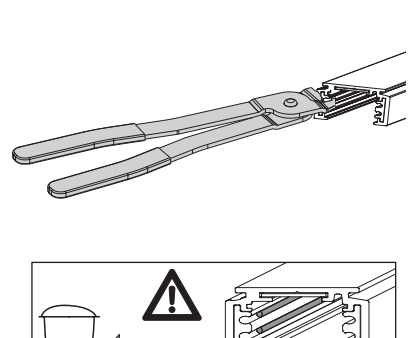
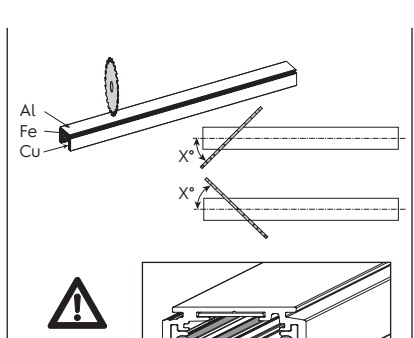
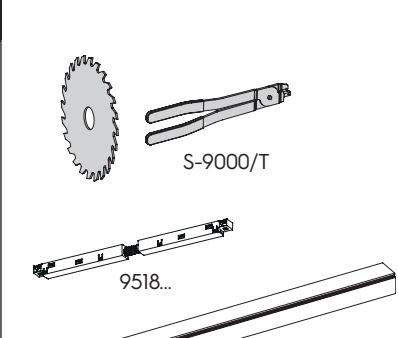
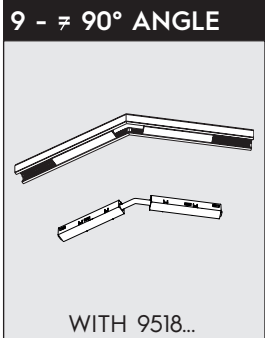

1

2

3

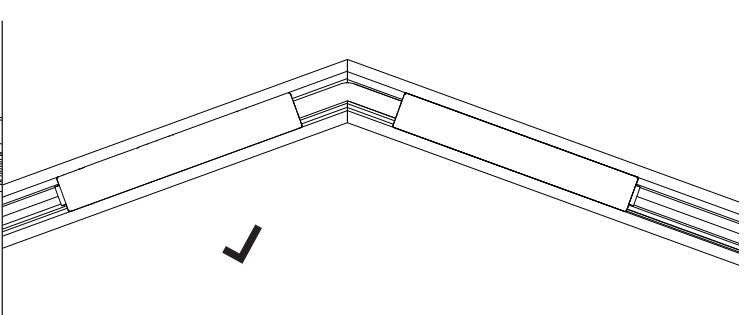
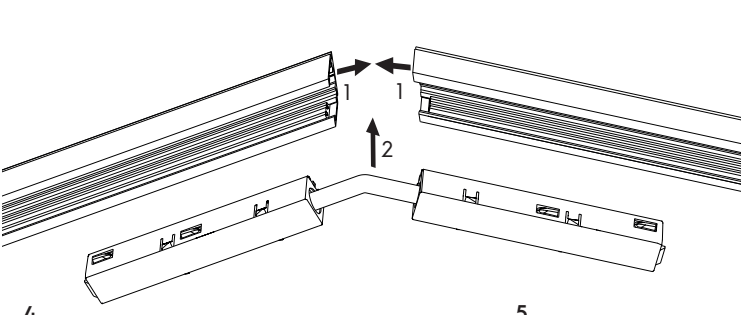

4

5

**10 - WALL CEILING
90° ANGLE**

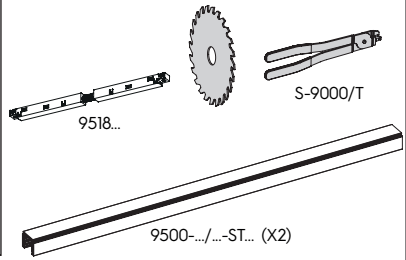

1

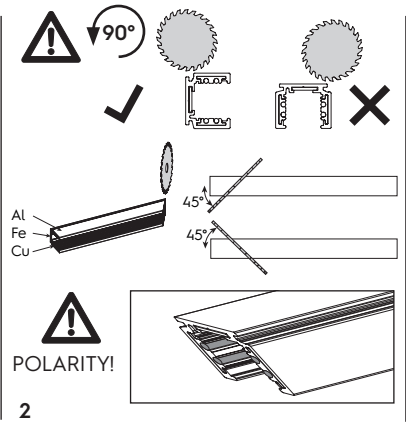

2

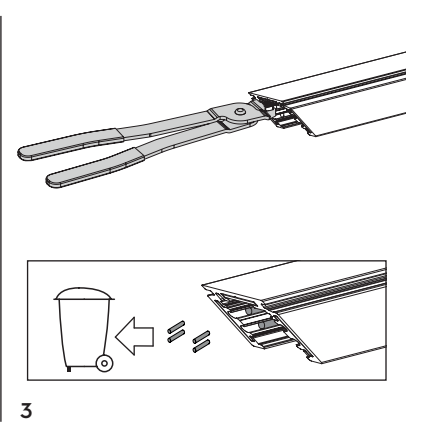

3

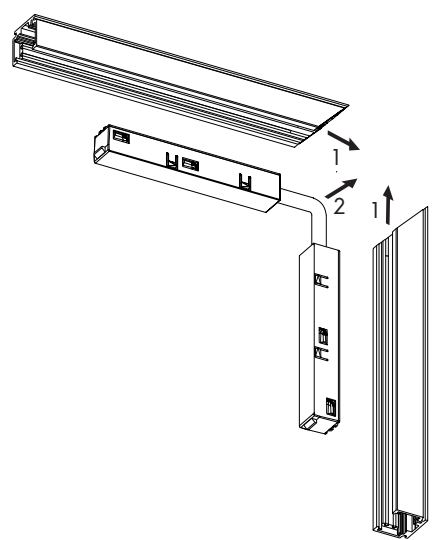

4

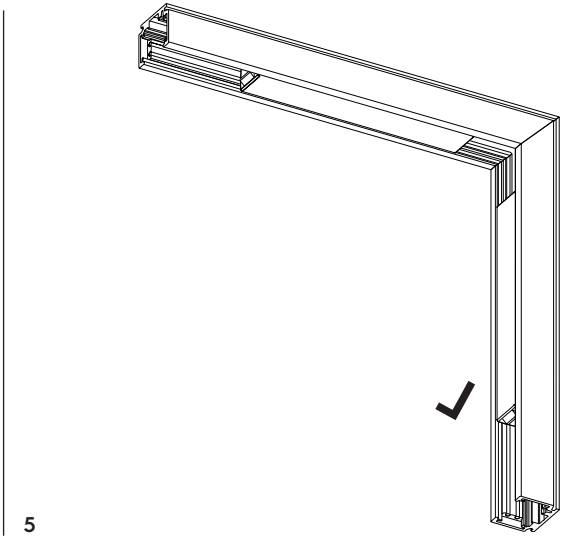

5