



SERIES 2410 - ERGONOMIC FOOT SWITCHES

TO 6 (2.5) A 250 V AC



PRODUCT FEATURES

- Long life endurance up to 300 000 mechanical switching cycles
- Robust design
- Cable can be retrofitted by customer
- Ergonomical dimensions with different operating forces
- With wall hanger

ON REQUEST

- Other colors
- Customized cable assembly
- Special switching functions
- Other terminal variants

| | |
|---------------------------|----------|
| Mechanical life endurance | 30E4 |
| Proof tracking | 250 PTI |
| Material actuator housing | PA PA |
| Approval marks | |

ROCKER SWITCHES

PUSHBUTTON SWITCHES

TOGGLE SWITCHES

SLIDE SWITCHES

ROTARY SWITCHES

FOOT SWITCHES

TACT AND KEY SWITCHES

SNAP-ACTION SWITCHES

MICRO-SIGNAL SWITCHES

SENSORS









ECO





PUSH-IN DRIVE











SERIES 2410 - ERGONOMIC FOOT SWITCHES

TO 6 (2.5) A 250 V AC

| | | | | | | | | | |
|---|---|---|---|----------------------|-----------------------|------------------|---------------------|-----------------------|---|
|  single-pole | Actuator color / printing | Housing color | Terminal type | Terminal description | Contact distance (mm) | Contact material | Operating force (N) | Miscellaneous | Stock version |
| | | 6 (2.5) A 250 V AC 5E4 | | | | | | | |
| Normally open contact (SPNO) | | | | | | | | | |
| 2410.0301 |  |  |  | 2 terminals M3 | < 3 | Ag | 31 ± 5 | with switch 1005.1801 |  |
| Changeover switch (SPDT momentary) | | | | | | | | | |
| 2410.0401 |  |  |  | M3 3 terminals | < 3 | Ag | 31 ± 5 | with switch 1005.1407 |  |

| | | | | | | | | | |
|--|---|---|---|----------------------|-----------------------|------------------|---------------------|--|---|
|  double-pole | Actuator color / printing | Housing color | Terminal type | Terminal description | Contact distance (mm) | Contact material | Operating force (N) | Miscellaneous | Stock version |
| | | 6 (2.5) A 250 V AC 5E4 | | | | | | | |
| Normally open contact (DPNO) | | | | | | | | | |
| 2410.1001 |  |  |  | assembled | ≥ 3 | Ag | 45 ± 7 N | 1 x PE connector (3 000 mm) / 1 x PE coupling (250 mm) 2 x 1005.1802 |  |

| | | | | | | | | | |
|---|---|---|---|----------------------|-----------------------|------------------|---|---|---|
|  Combination | Actuator color / printing | Housing color | Terminal type | Terminal description | Contact distance (mm) | Contact material | Operating force (N) | Miscellaneous | Stock version |
| | | 6 (2.5) A 250 V AC 5E4 | | | | | | | |
| Normally closed contact (SPNC) / Changeover switch (SPDT momentary) | | | | | | | | | |
| 2410.0101 |  |  |  | M3 3 terminals | < 3 | Ag | step 1: 25 ± 5 N / step 2: 85 ± 15 N | with switch 1005.1407 with switch 1005.1501 switching in sequence | |
| Normally open contact (SPNO) / Changeover switch (SPDT momentary) | | | | | | | | | |
| 2410.0501 |  |  |  | M3 5 terminals | < 3 | Ag | step 1: 22 N ± 4 / step 2: 31 ± 5 N | with switch 1005.1407 with switch 1005.1801 switching in sequence Changeover switch and normally open contact can be connected separately |  |

ROCKER SWITCHES

PUSHBUTTON SWITCHES

TOGGLE SWITCHES

SLIDE SWITCHES

ROTARY SWITCHES

FOOT SWITCHES

TACT AND KEY SWITCHES

SMAP-ACTION SWITCHES

MICRO-SIGNAL SWITCHES

SENSORS

ECO

PUSH/NDRIVE



SERIES 2410 - ERGONOMIC FOOT SWITCHES

TO 6 (2.5) A 250 V AC

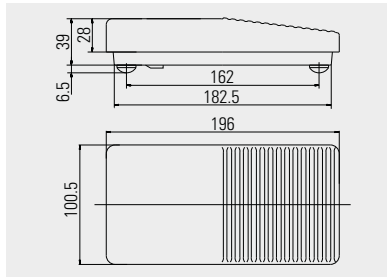

Basic type 2410

Socket terminal
2 terminals M3

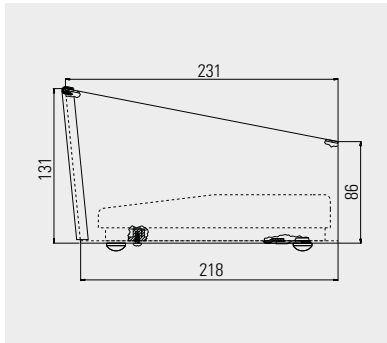

Protection hood
248.008.013

Steel plate protection hood in orange color similar to RAL 2004 with edge guard and rubber feet as well as fixation for foot switch of the basic type 2410

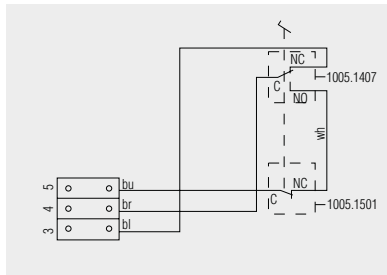

2410.0101

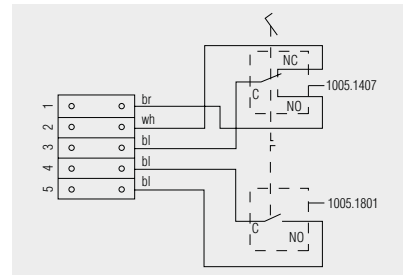

2410.0501

Circuit diagram

- bu - blue
- br - brown
- bl - black
- wh - white
- C - common terminal
- NC - normally closed contact
- NO - normally open contact

ROCKER SWITCHES
PUSHBUTTON SWITCHES
TOGGLE SWITCHES
SLIDE SWITCHES
ROTARY SWITCHES
FOOT SWITCHES
TACT AND KEY SWITCHES
SWAP-ACTION SWITCHES
MICRO-SIGNAL SWITCHES
SENSORS
ECO
PUSH/DRIVE

MARQUARDT INTERNATIONAL.

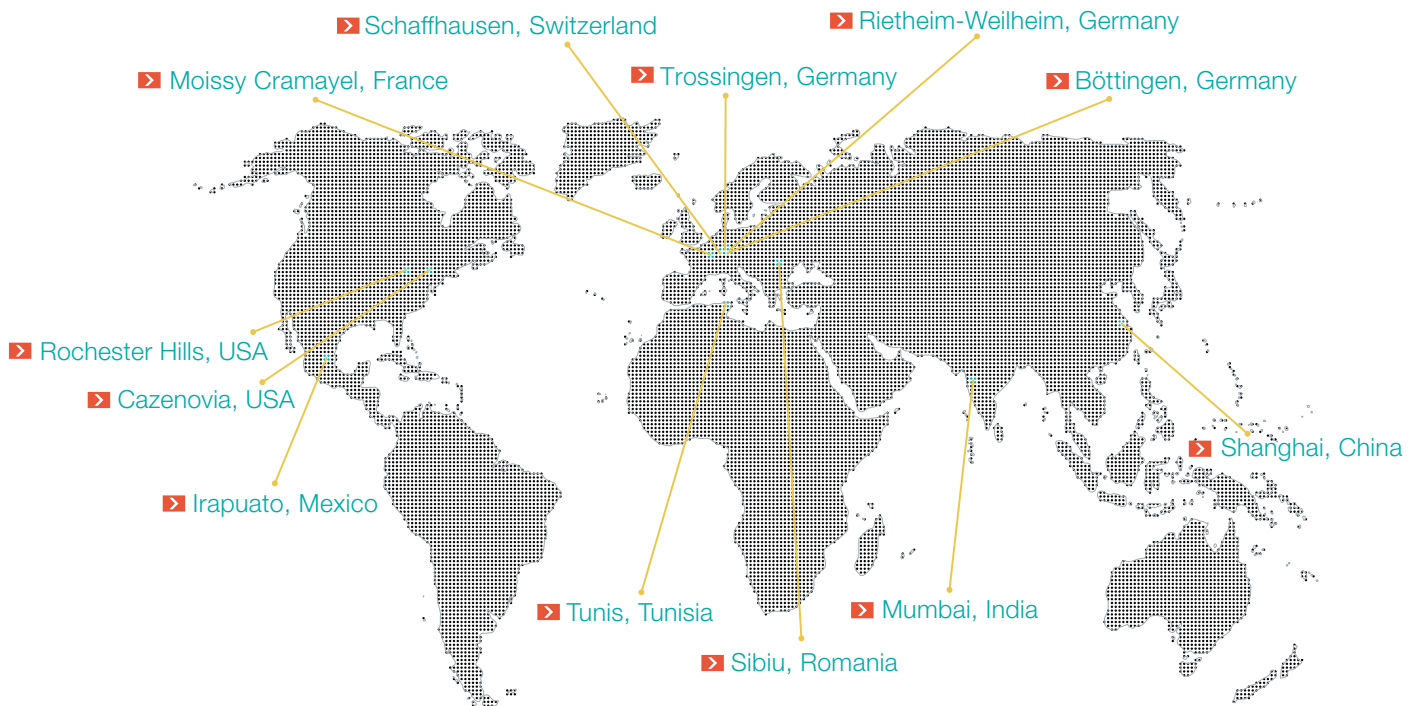

HEADQUARTERS

Marquardt Mechatronik GmbH

Schloss-Straße 16
78604 Rietheim-Weilheim / GERMANY
Tel. +49 (0)74 24/99-0
Fax +31 (0)74 24/99-2399
marquardt@marquardt.com
www.marquardt.com

Geuken



DISTRIBUTOR

GEUKEN B.V.

Wattstraat 25a
2723 RA Zoetermeer / NETHERLANDS
Tel. +31 (0)79 361 60 70
Fax +31 (0)79 361 40 90
info@geuken.nl
www.geuken.nl