

## ➔ SERIES 1660 - SINGLE AND DOUBLE-POLE PUSHBUTTON SWITCHES

TO 16 (4) A 250 V AC



### PRODUCT FEATURES

- ➔ Illuminated and non-illuminated pushbutton switches
- ➔ Proven jump contact switching system (double interrupting)
- ➔ Opening and closing speed independent of the actuating speed
- ➔ Product-dependent with external lamp terminal

### ON REQUEST

- ➔ Other colors
- ➔ Other printing variants
- ➔ Other terminal types
- ➔ Other lamp variants
- ➔ Cable assembly

<b>Mechanical life endurance</b>	5E4
<b>Contact resistance (new condition)</b>	< 100 mOhm (1 A 12 V DC)
<b>Insulation resistance (new condition)</b>	> 100 MOhm (500 V DC)
<b>Proof tracking</b>	250 PTI
<b>Protection type</b>	IP 40
<b>Ambient temperature</b>	terminal side -20 °C ... +85 °C actuating side -20 °C ... +55 °C
<b>Flammability</b>	UL 94 V-2
<b>Glow wire test temperature</b>	850 °C
<b>Material</b>	actuator housing terminals
	PC (product-dependent) / PA PA / PA glass fiber-reinforced (product-dependent) Cu
<b>Plug force of the terminals</b>	≤ 80 N
<b>Approval marks</b>	UL / VDE / CE (product-dependent) / RoHS
<b>Suitable for appliances of protection class II</b>	



# SERIES 1660 - SINGLE AND DOUBLE-POLE PUSHBUTTON SWITCHES

TO 16 (4) A 250 V AC

 single-pole		Lighting voltage (V)	Actuator color / printing	Housing color	16 (4) A 250 V AC 1E4	16 (4) A 250 V AC	12 (4) A 250 V AC 1E4	12 A 250 V AC 1/2 HP	12 A 125 V AC 1/6 HP	Terminal type	Terminal description	Contact distance (mm)	Contact material	Miscellaneous	Stock version
<b>ON / OFF switch (SPST)</b>															
1662.0201					o						6.3	≥ 3	Ag		
<b>Normally open contact (SPNO)</b>															
1665.3102	230				o						6.3 / 2 x 4.8	≥ 3	Ag	external lamp terminal	
1662.0101					o						6.3	≥ 3	Ag		o
<b>Changeover switch (SPDT momentary)</b>															
1664.0101						o					4.8	< 3	Ag		





 double-pole		Lighting voltage (V)	Actuator color / printing	Housing color	16 (4) A 250 V AC 1E4	16 (4) A 250 V AC	12 (4) A 250 V AC 1E4	12 A 250 V AC 1/2 HP	12 A 125 V AC 1/6 HP	Terminal type	Terminal description	Contact distance (mm)	Contact material	Miscellaneous	Stock version
<b>ON / OFF switch (DPST)</b>															
1660.0201	230				o						6.3	≥ 3	Ag		o
1660.0202	230				o						6.3	≥ 3	Ag		o
1660.3202	230				o						6.3 / 2 x 4.8	≥ 3	Ag	external lamp terminal	
1660.0222	110								o		6.3	≥ 3	Ag		
1661.0220						o	o	o			6.3	≥ 3	Ag		
<b>Normally open contact (DPNO)</b>															
1661.0101					o						6.3	≥ 3	Ag		o
<b>Changeover switch (DPDT momentary)</b>															
1663.0101						o					4.8	< 3	Ag		o

ROTARY SWITCHES  
 PUSHBUTTON SWITCHES  
 TOGGLE SWITCHES  
 SLIDE SWITCHES  
 ROTARY SWITCHES  
 FOOT SWITCHES  
 TACT AND KEY SWITCHES  
 SNAP-ACTION SWITCHES  
 MICRO-SIGNAL SWITCHES  
 SENSORS  
 ECO  
 PUSH-IN DRIVE



# SERIES 1660 - SINGLE AND DOUBLE-POLE PUSHBUTTON SWITCHES

TO 16 (4) A 250 V AC

	Lighting voltage (V)	Actuator color / printing	Housing color	Terminal type	Terminal description	Contact distance (mm)	Contact material	Miscellaneous	Stock version
 Lamp									
<b>Lamp</b>									
1667.0101	230				6.3				
1667.0102	230				6.3				



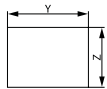

Basic types 1660, 1661 and 1663 double-pole illuminated / non-illuminated

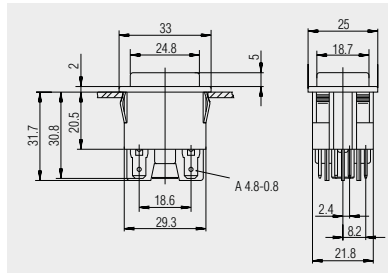

X = Wall thickness

x	y	z
0.75 ... 1.0	30 <sup>+0.1</sup>	22.2 <sup>+0.2</sup>
1.0 ... 1.5	30.2 <sup>+0.1</sup>	22.2 <sup>+0.2</sup>
1.5 ... 3.0	30.4 <sup>+0.1</sup>	22.2 <sup>+0.2</sup>



 Quick-connect terminal 4.8 x 0.8

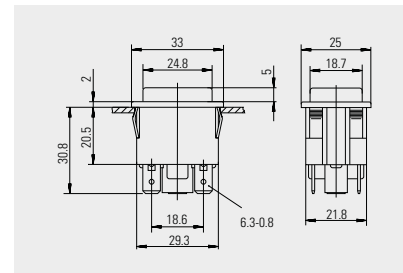

 Quick-connect terminal 6.3 x 0.8

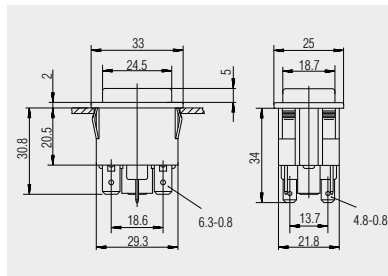

 Quick-connect terminal 6.3 x 0.8 / 2 x 4.8 x 0.8 with external lamp terminal



# SERIES 1660 - SINGLE AND DOUBLE-POLE PUSHBUTTON SWITCHES

TO 16 (4) A 250 V AC



Basic type 1667  
lamp

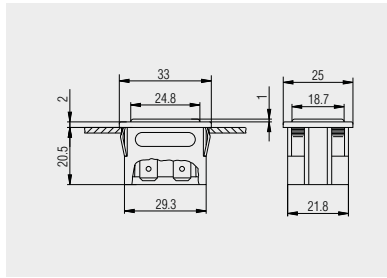

Quick-connect terminal 6.3 x 0.8

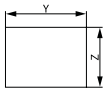

X = Wall thickness

x	y	z
0.75 ... 1.0	30 <sup>+0.1</sup>	22.2 <sup>+0.2</sup>
1.0 ... 1.5	30.2 <sup>+0.1</sup>	22.2 <sup>+0.2</sup>
1.5 ... 3.0	30.4 <sup>+0.1</sup>	22.2 <sup>+0.2</sup>



Gasket  
340.040.011

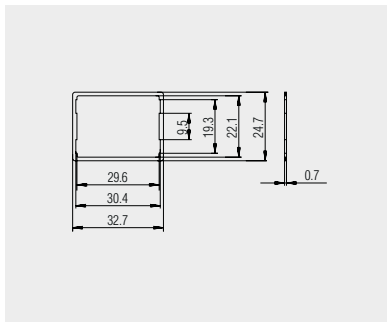

Gasket made of EPDM black for sealing between switch and appliance for increased dust and water protection



Protection cap  
203.201.011

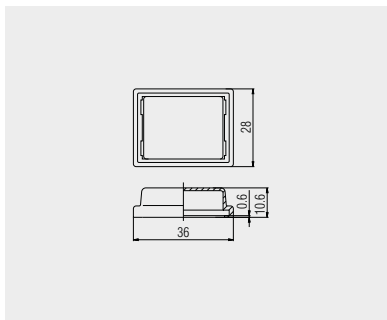

Transparent PVC-protection cap for switches of the basic types 1660, 1662, 1663, 1664, 1665 and 1667. Serves as dust and water protection of the actuation side.



Dummy piece  
203.028.013

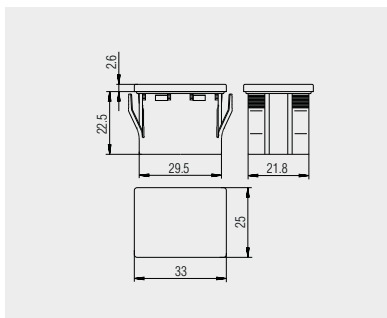

Dummy piece for size of basic type 1667 made of PA with housing and cover in black and with mounted gasket (340.040.011) for dust and water protection.

ROCKER SWITCHES  
PUSHBUTTON SWITCHES  
TOGGLE SWITCHES  
SLIDE SWITCHES  
ROTARY SWITCHES  
FOOT SWITCHES  
TACT AND KEY SWITCHES  
SNAP-ACTION SWITCHES  
MICRO-SIGNAL SWITCHES  
SENSORS  
ECO  
PUSH IN DRIVE

# MARQUARDT INTERNATIONAL.

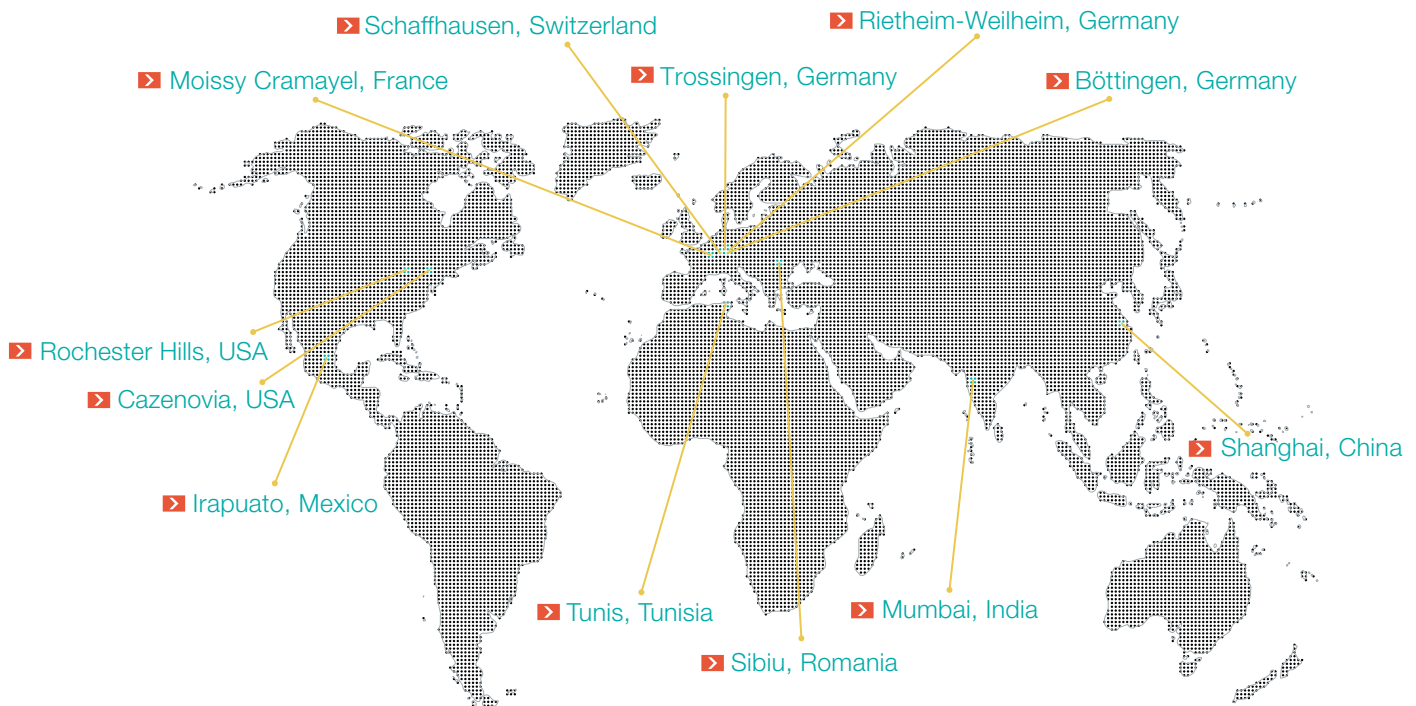

## HEADQUARTERS

### Marquardt Mechatronik GmbH

Schloss-Straße 16

78604 Rietheim-Weilheim / GERMANY

Tel. +49 (0)74 24/99-0

Fax +31 (0)74 24/99-2399

marquardt@marquardt.com

[www.marquardt.com](http://www.marquardt.com)

## Geuken



## DISTRIBUTOR

### GEUKEN B.V.

Wattstraat 25a

2723 RA Zoetermeer / NETHERLANDS

Tel. +31 (0)79 361 60 70

Fax +31 (0)79 361 40 90

info@geuken.nl

[www.geuken.nl](http://www.geuken.nl)